

HAFCO WOODMASTER



Edition : 2.0
Date: (11/25)

Instruction Manual

PLANER THICKNESSER PT-254S, PT-305S

Order Code: (W611, W612)

MACHINE DETAILS

MACHINE	PLANER THICKNESSER
MODEL NO.	
SERIAL NO.	
DATE OF MANF.	
CUTTERHEAD	HSS - INSERTS SPIRAL

DISTRIBUTED BY



www.machineryhouse.com.au
www.machineryhouse.co.nz

NOTE:

This manual is only for your reference. Owing to the continuous improvement of the HAFCO machines, changes may be made at any time without obligation or notice. Please ensure the local voltage is the same as listed on the specification plate before operating this electric machine.



NOTE:

In order to see the type and model of the machine, please see the specification plate. Usually found on the back of the machine. See example (Fig.1)

FIG.1

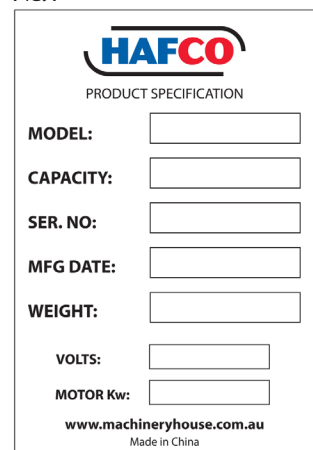

CONTENTS:

1. GENERAL MACHINE INFORMATION	
1.1 Specifications	4
1.2 Standard equipment.....	5
1.3 Identification PT-254S.....	6
Identification PT-305S.....	7
Identification drive Rollers & cutter head.....	9
2. IMPORTANT INFORMATION	
2.1 General machinery safety	12
2.2 Additional safety for planer thicknessers	14
2.3 Lifting and placement	17
2.4 Electrical installation.....	17
2.5 Full load current rating.....	17
3. SETUP	
3.1 Assembly	18
Emergency stop lever assembly	19
Cutter block side guard.....	19
Overhead cutter guard mounting arm	19
Mounting the fence.....	20
3.2 Setting surface tables and cutter block	21
Setting the fence at 90°	21
Setting the 90° fence stop.....	21
Setting the 45° fence stop.....	22
3.3 Setting the outfeed Surface Table.....	22
3.4 Setting the infeed Surface Table.....	23
3.5 Setting the thickening table stop	23
3.6 Setting the thickening table extension	24
4. OPERATING INSTRUCTIONS	
4.1 Setting the machine for planing.....	24
4.2 Setting the machine for thickening.....	25
4.3 Emergency stop.....	25
4.4 Troubleshooting	26
5. MAINTENANCE	
5.1 Changing the cutter block blades.....	28
5.2 Spiral cutter blocks	29
5.3 Maintenance Schedule	30
5.4 Adjusting belt and chain drive	31
5.5 Re-tightening the table lock down handles..	32
5.6 Setting the feed rollers tension.....	33
Spare parts.....	34

1.1. SPECIFICATIONS

Order Code	W611	W612
MODEL	PT-254S	PT-305S
Power (kW)	2.2	3.0
Voltage	240V 1ph	240V 1ph
Feed Speed (m/min)	5	5
Cutter Head Speed (R.P.M.)	4800	4800
Cutter Block Diameter (mm)	70	70
Max. Thicknesser Height Capacity (mm)	190	225
Max. Planer Width (mm)	255	310
Max. Depth of Cut Thicknesser (mm)	2 @ 140	2 @ 140
Max. Full Width Depth of Cut Thicknesser (mm)	1.5	1.0
Max. Depth of Cut Planer (mm)	3	4
Cutter Type	HSS Inserts-Spiral	HSS Inserts-Spiral
Quantity of Cutters	44 inserts	56 inserts
Length of Table (mm)	1100	1380
Min. Extraction Airflow Required (m ³ /hr)	1000	1500
Dust Extraction Outlet (mm)	100	100
Overall Dimensions (L x W x H) (mm)	1100 x 660 x 940	1385 x 705 x 1000
Weight (Kg)	182	272



Spiral Cutter Block

1.2. STANDARD EQUIPMENT

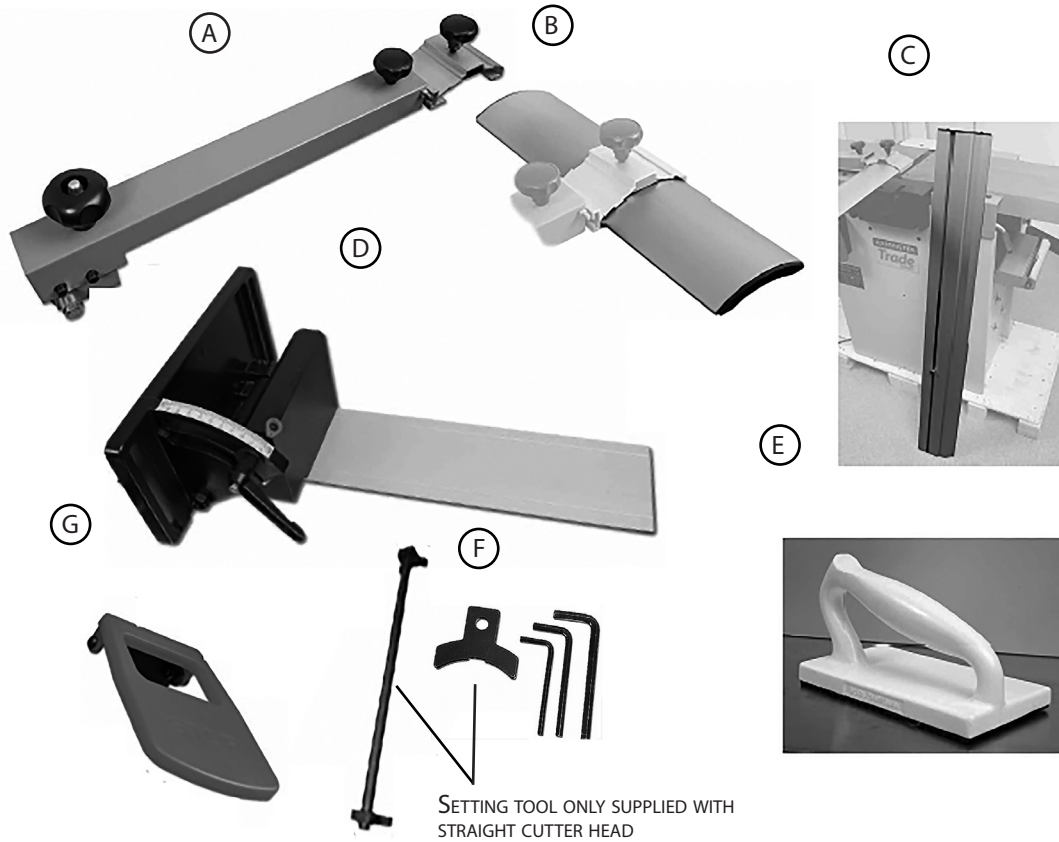

A	Arm Assembly	F	Hex. Keys & Straight Blade Setting Tool
B	Cutter Block Cover	G	Emergency Stop Lever (PT-254S)
C	Fence	H	Fence Assembly Mounting Bracket
D	Fence Tilt Assembly	I	Lift & Shift Handles with M8 threads
E	Push Guide Block	J	Cutter Block Side Guard

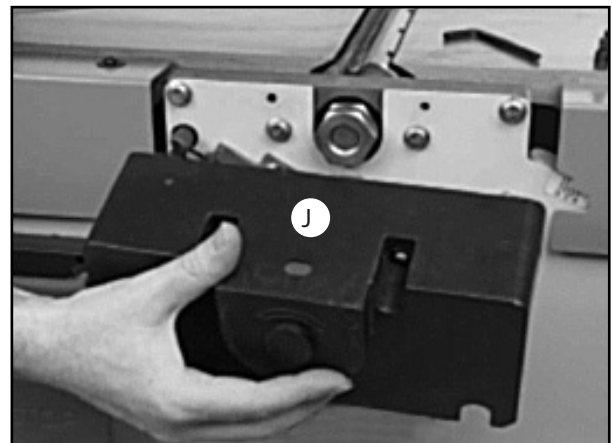
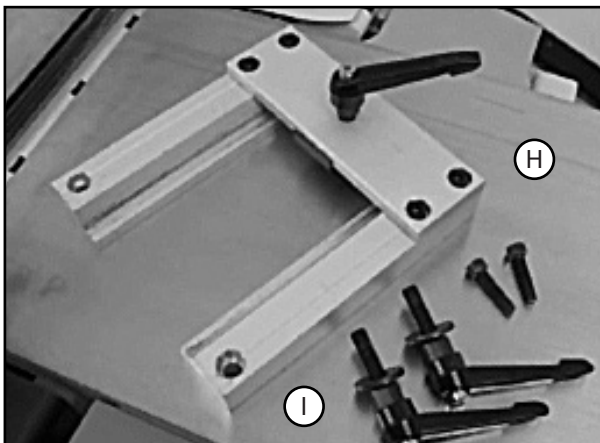

1.3 IDENTIFICATION PT254S

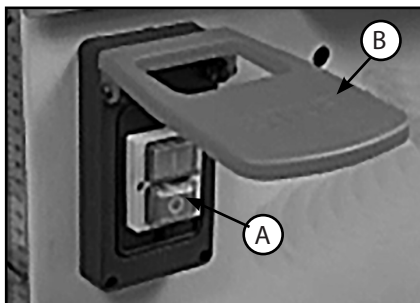
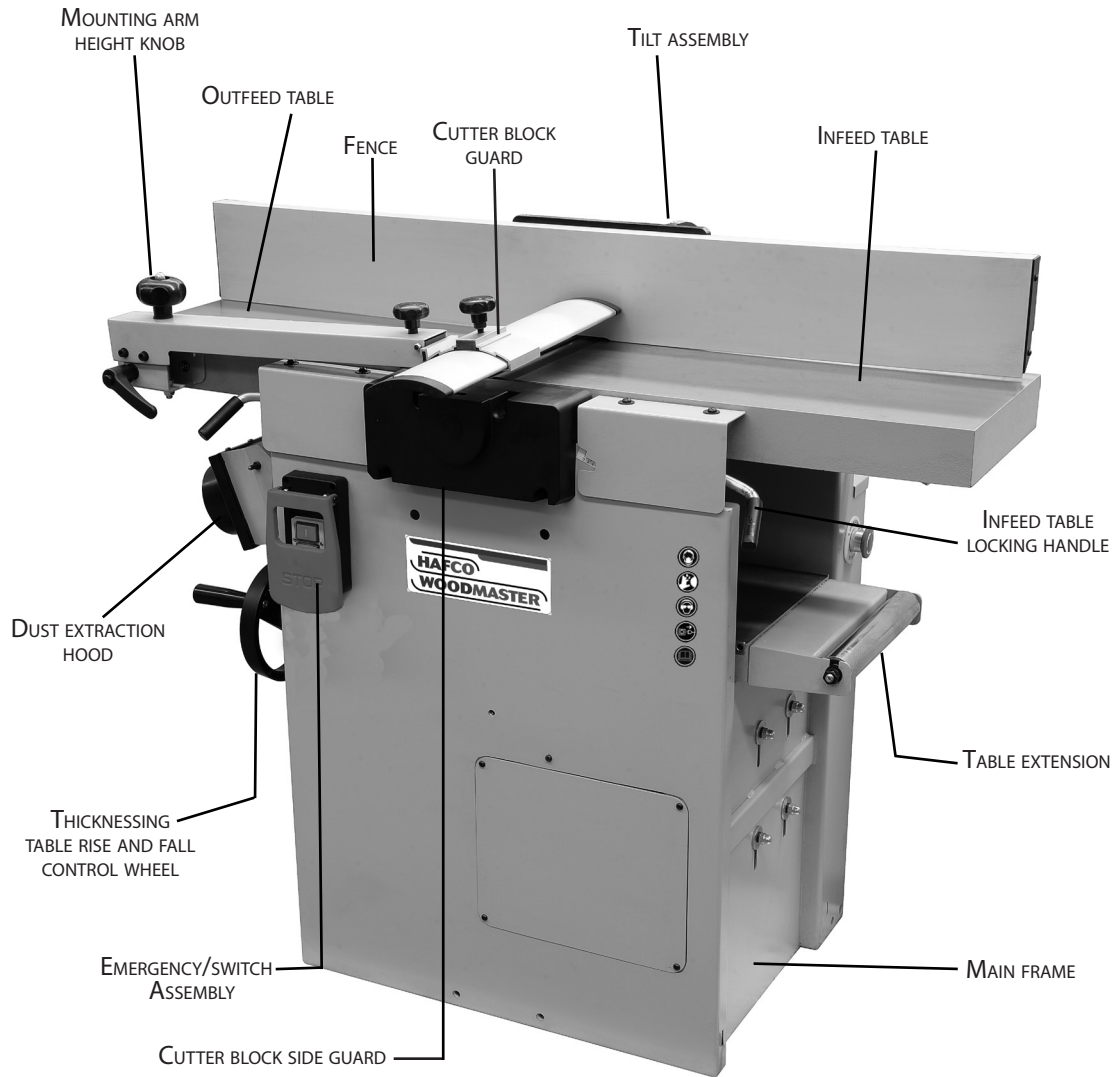

SWITCH ASSEMBLY (A)
EMERGENCY STOP SHROUD LEVER (B)

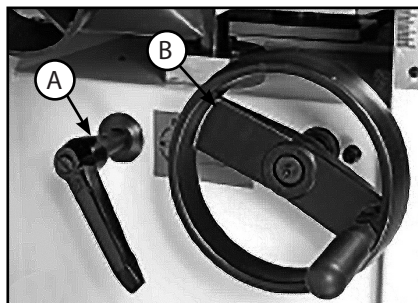

THICKENING TABLE RISE AND
FALL CLAMPING HANDLE (A)
THICKENING TABLE RISE AND
FALL CONTROL WHEEL (B)

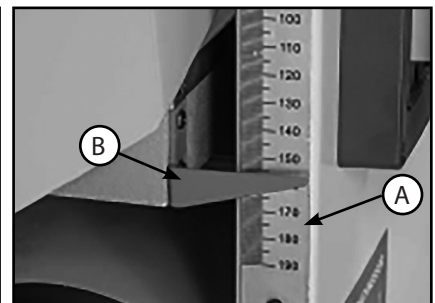

THICKENING TABLE RISE AND FALL SCALE (A)
TABLE POINTER (B)

1.3 IDENTIFICATION PT305S

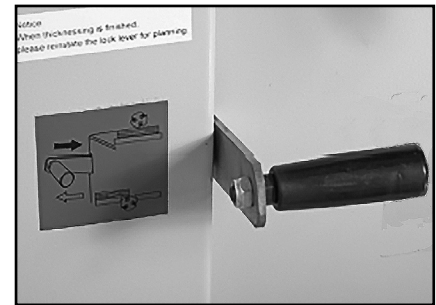
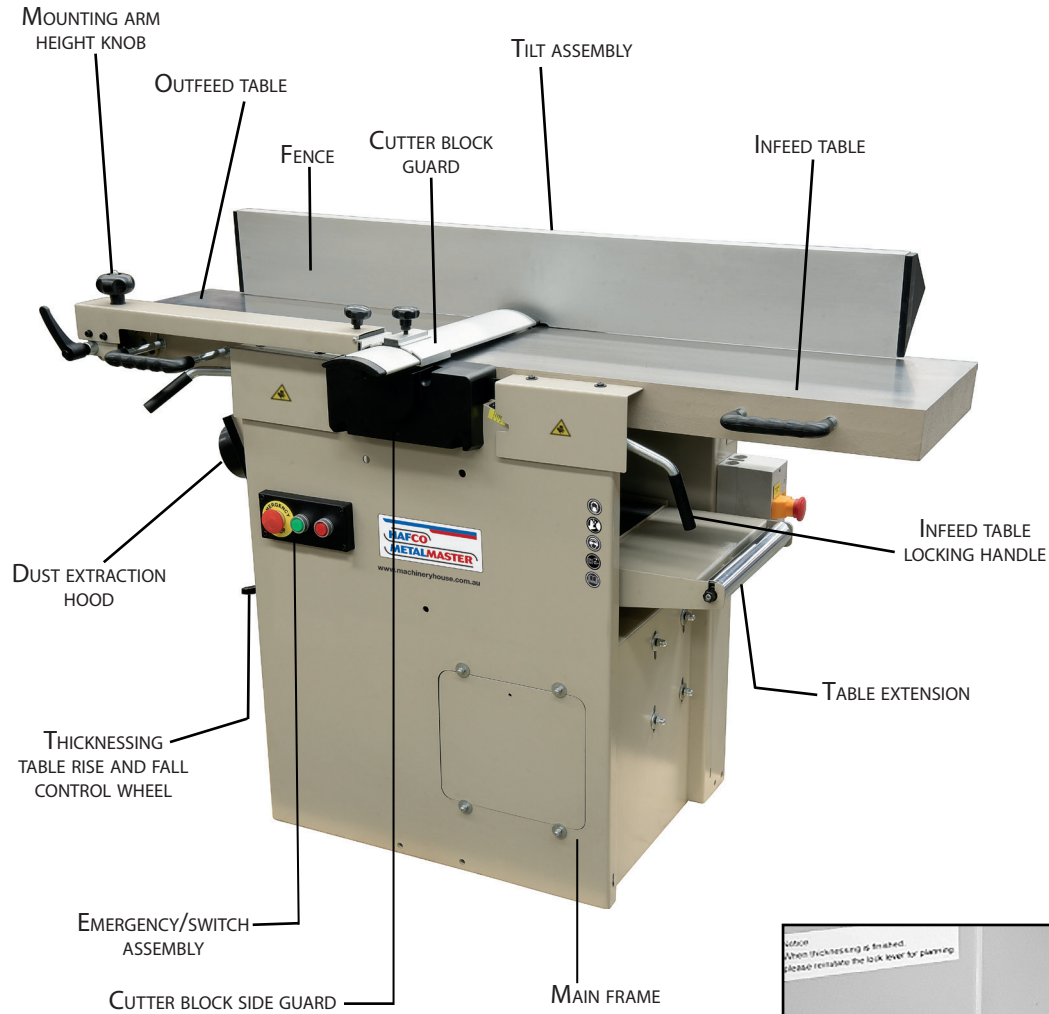

PLANING OR THICKENING SELECTION LEVER

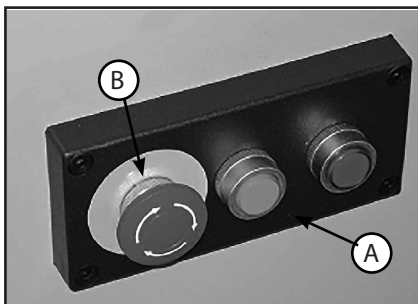

SWITCH ASSEMBLY (A)
EMERGENCY STOP BUTTON (B)

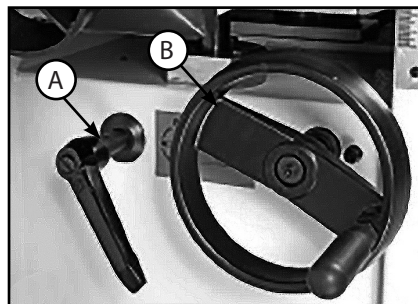

THICKENING TABLE RISE AND FALL CLAMPING HANDLE (A)
THICKENING TABLE RISE AND FALL CONTROL WHEEL (B)

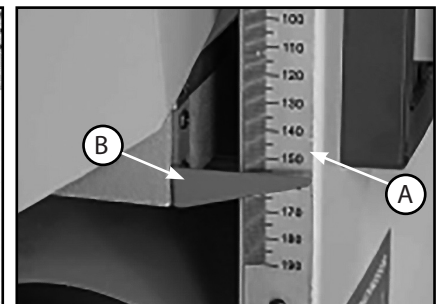

THICKENING TABLE RISE AND FALL SCALE (A)
TABLE POINTER (B)

1.3 IDENTIFICATION CONT.

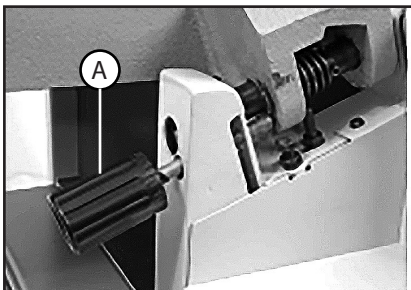
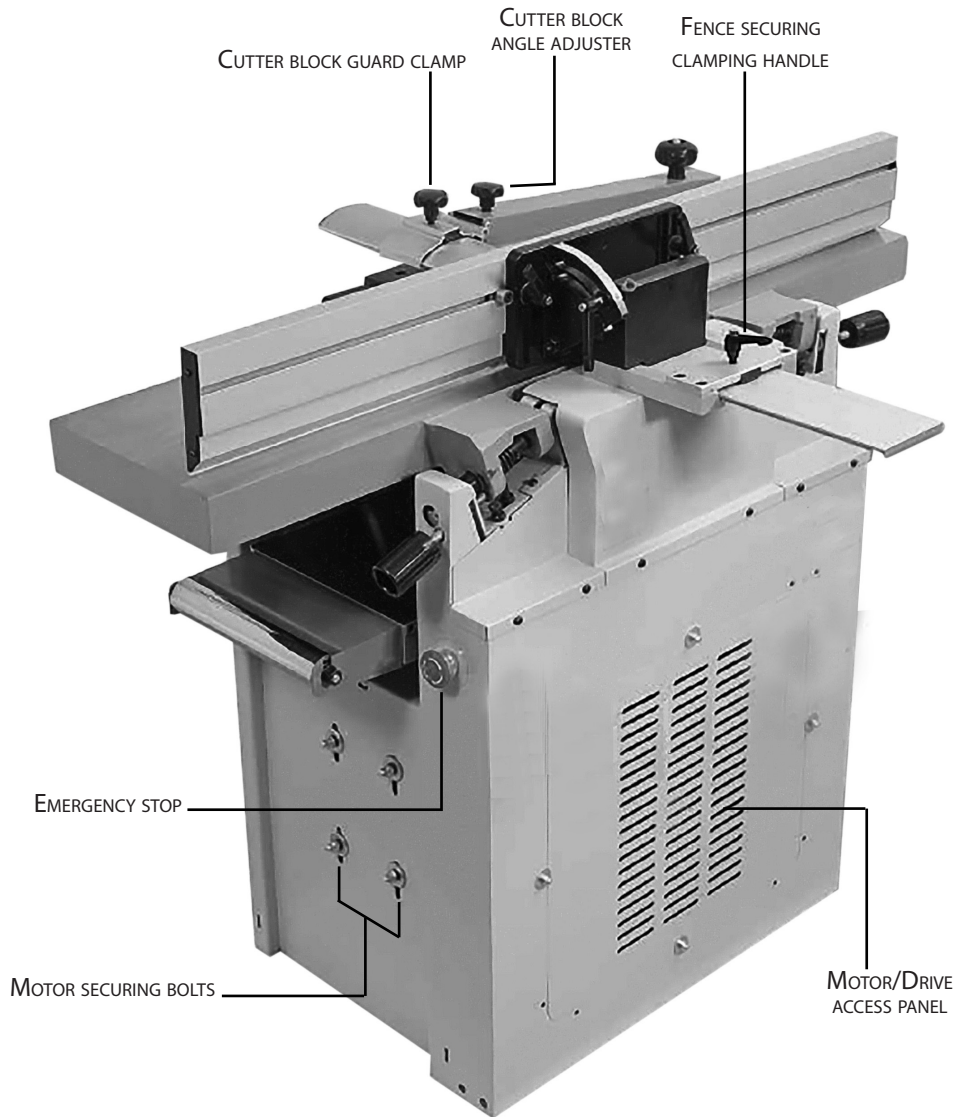

OUTFEED TABLE ADJUSTER (A)

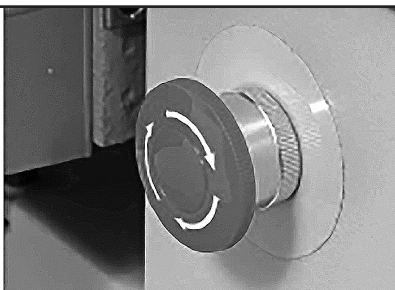

EMERGENCY STOP

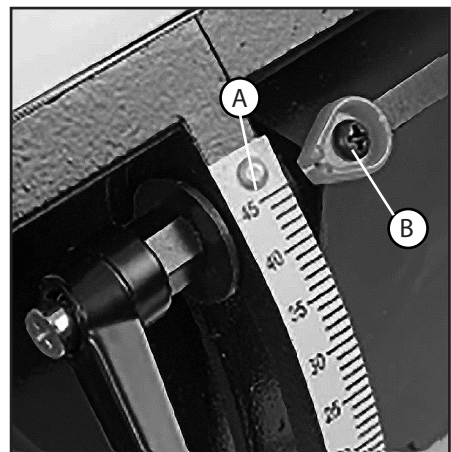

FENCE ANGLE POINTER SET TO 45° (A)
POINTER ADJUSTING SCREW (B)

1.3 IDENTIFICATION CONT.

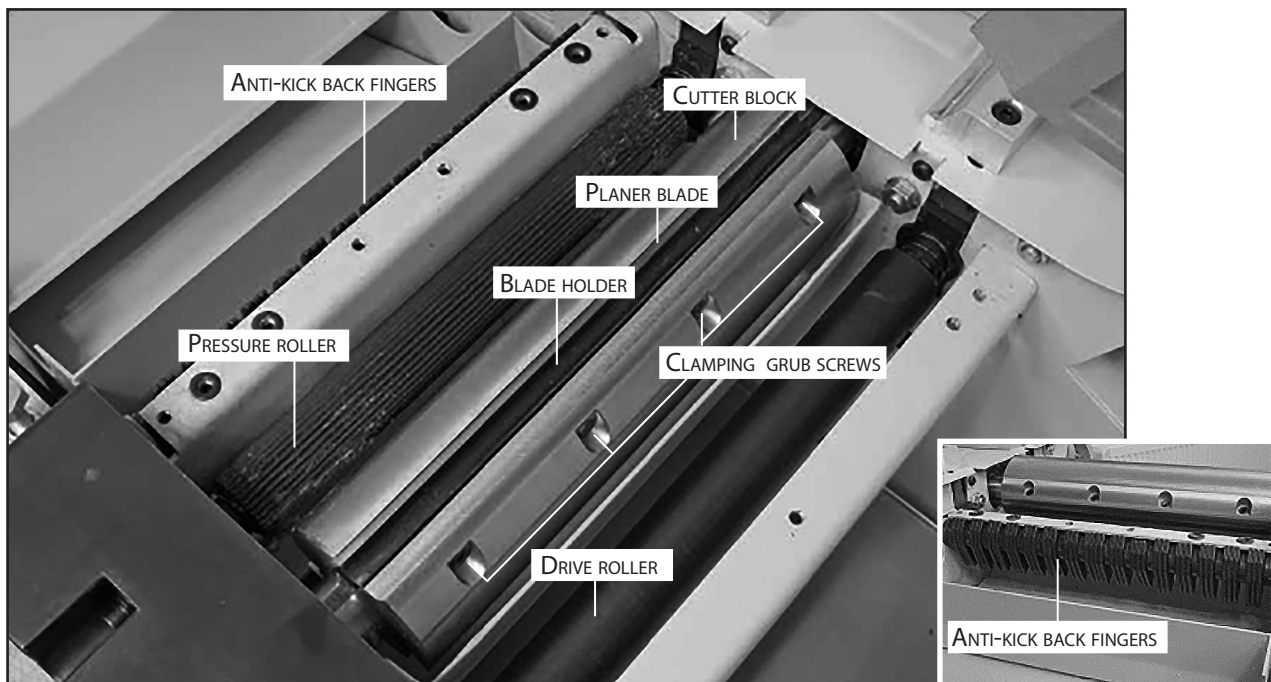
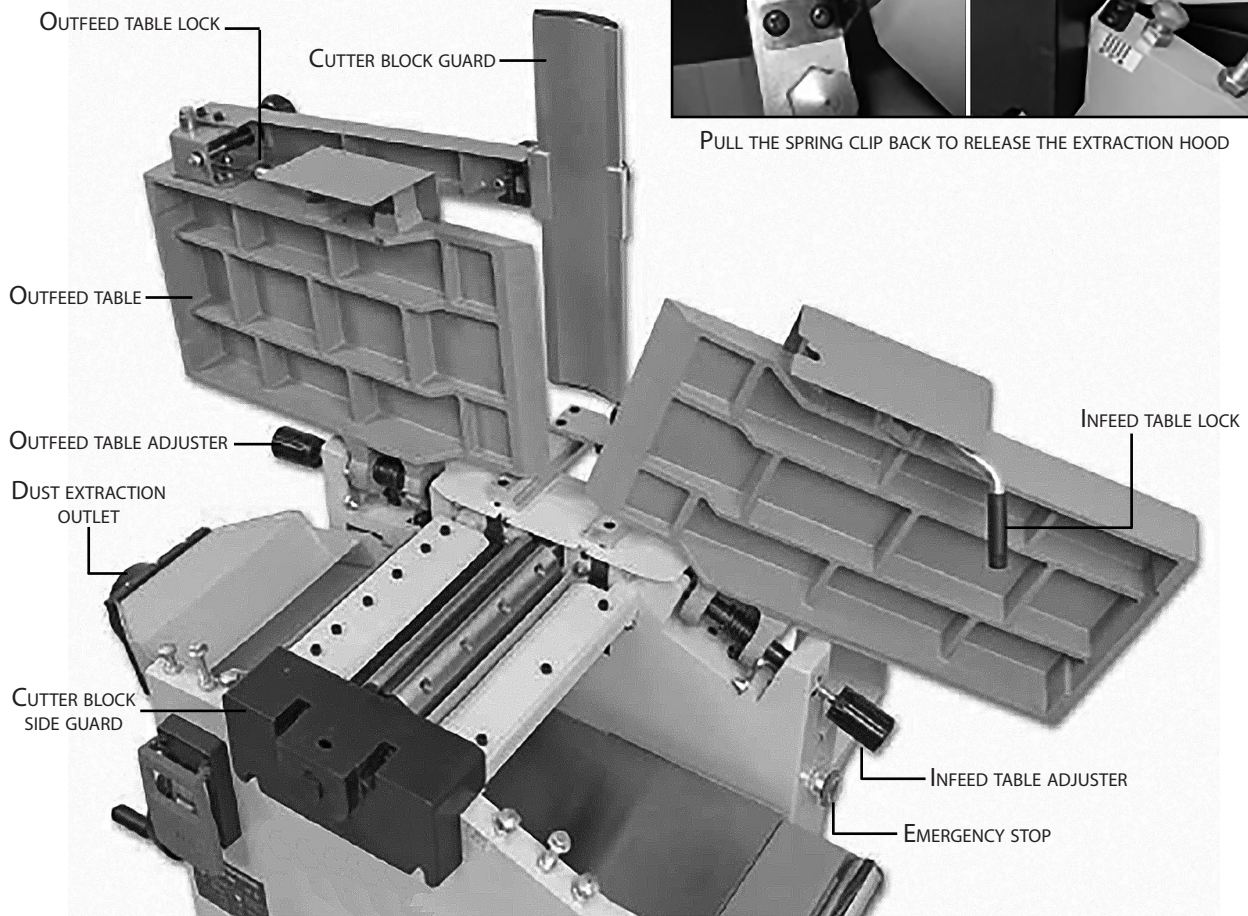

1.3 IDENTIFICATION CONT.

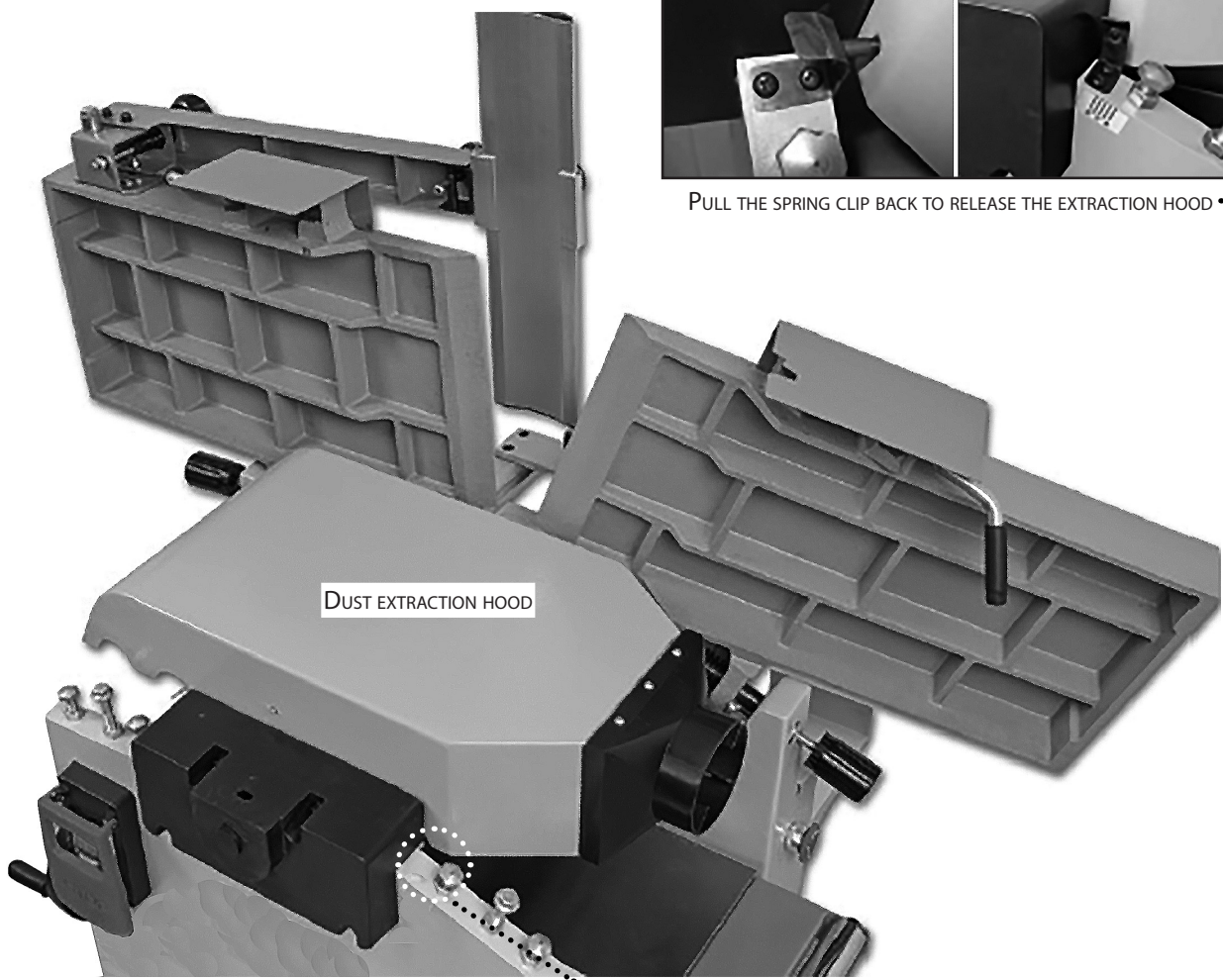

SPIRAL CUTTER BLOCK

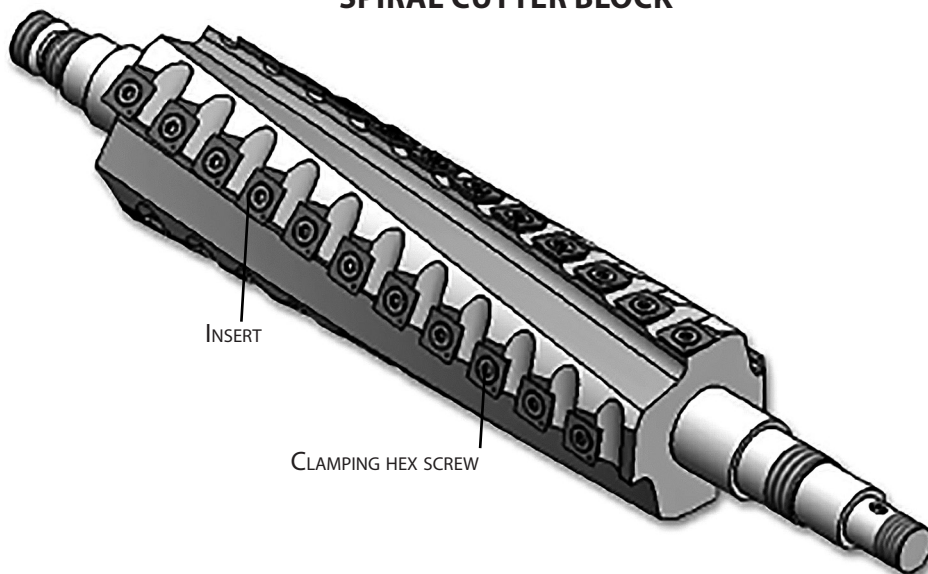

1.3 IDENTIFICATION CONT.

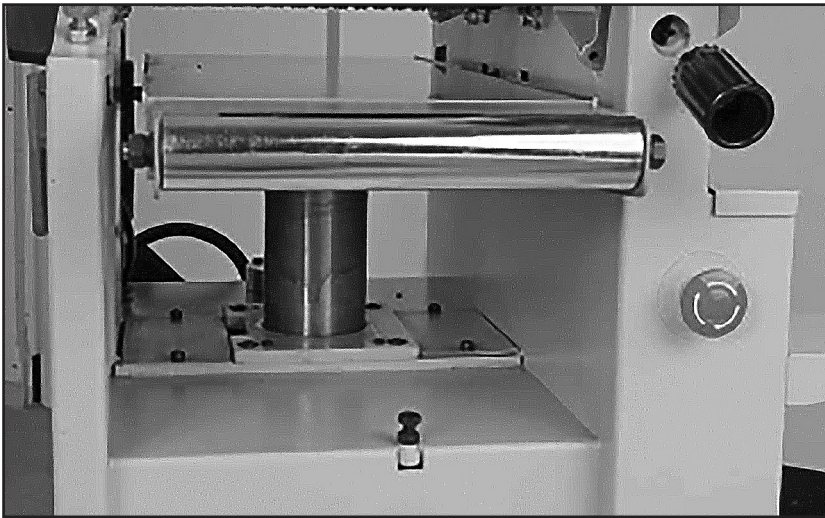

THICKENING TABLE ASSEMBLY



THICKENING TABLE ASSEMBLY STOP

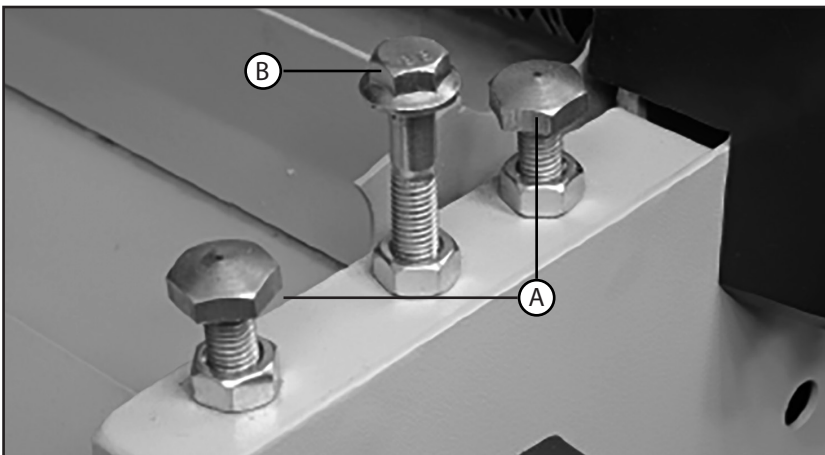

TABLE POSITIONING STUDS (A), TABLE LOCK STUD (B)

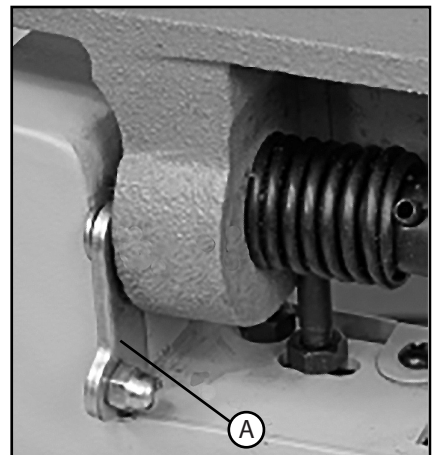

TABLE LOCKING BAR (A)



FOUR SIDED SPIRAL CUTTER BLOCK WITH HSS INSERTS



INFEED TABLE PLANNING SCALE

2.1 GENERAL WOODWORKING MACHINE SAFE PRACTICES

DO NOT use this machine unless you have read this manual or have been instructed in the use of this machine in its safe use and operation



WARNING

This manual provides safety instructions on the proper setup, operation, maintenance, and service of this machine. Save this manual, refer to it often, and use it to instruct other operators.

Failure to read, understand and follow the instructions in this manual may result in fire or serious personal injury—including amputation, electrocution, or death.

The owner of this machine is solely responsible for its safe use. This responsibility includes, but is not limited to proper installation in a safe environment, personnel training and authorization to use, proper inspection and maintenance, manual availability and comprehension, of the application of the safety devices, integrity, and the use of personal protective equipment.

The manufacturer will not be held liable for injury or property damage from negligence, improper training, machine modifications or misuse.



Exposure to the dust created by power sanding, sawing, grinding, drilling and other construction activities may cause serious and permanent respiratory or other injury, including silicosis (a serious lung disease), cancer, and death. Avoid breathing the dust, and avoid prolonged contact with dust. Some examples of these chemicals are:



- Lead from lead-based paints.
- Crystalline silica from bricks, cement and other masonry products.
- Arsenic and chromium from chemically-treated timber.

Always operate tool in well ventilated area and provide for proper dust removal. Use a dust collection system along with an air filtration system whenever possible. Always use properly fitting approved respiratory protection appropriate for the dust exposure, and wash exposed areas with soap and water.

- ✓ Always wear safety glasses or goggles and protective footwear.
- ✓ Wear dust masks when required.
- ✓ Wear hearing protection that is suitable for the level and frequency of the noise you are exposed to in the woodworking area. If you have trouble hearing someone speak from three feet away, the noise level from the machine may be hazardous.
- ✓ Use gloves to protect hands from splinters when handling wood but do not wear them near rotating blades and other machinery parts where the gloves can catch.

2.1 GENERAL WOODWORKING MACHINE SAFE PRACTICES Cont.

- ✓ Make sure guards are in position, in good working condition, and guards the operator adequately before operating any equipment or machine. Check and adjust all other safety devices.
- ✓ Make sure the equipment is properly grounded before use.
- ✓ Check that keys and adjusting wrenches are removed from the machine before turning on.
- ✓ Inspect stock for nails or other materials before cutting, planing, routing or carrying out similar activities.
- ✓ Make sure that all machines have start and stop buttons within easy and convenient reach of an operator. Start buttons should be protected so that accidental contact will not start machine.
- ✓ Ensure that all cutting tools and blades are clean, sharp, and in good working order so that they will cut freely, not forced.
- ✓ Turn the power off and unplug the power cord (or lock out the power source) before inspecting, changing, cleaning, adjusting or repairing a blade or a machine.
- ✓ Use a "push stick" to push material into the cutting area. Jigs are also useful in keeping hands safe during cutting procedures. Keep hands out of the line of the cutting blade.
- ✓ Always use a push stick for pieces less than 30 cm (1 ft) in length, or for the last 30 cm of a long cut
- ✓ Use a push stick to remove the cut piece from between the fence and the blade.
- ✓ Clamp down and secure all work pieces when drilling or milling.
- ✓ Use good lighting so that the work piece, cutting blades, and machine controls can be seen clearly. Position or shade lighting sources so that they do not shine in the operator's eyes or cause any glare and reflections.
- ✓ Ensure that the floor space around the equipment is sufficient to enable you to machine the size of work piece being processed safely without bumping into other workers or equipment.
- ✓ Woodworking machines should be fitted with efficient and well-maintained local exhaust ventilation systems to remove sawdust or chips that are produced.
- ✓ Electric power cords should be above head level or in the floor in such a way that they are not tripping hazards.
- ✓ Keep work area free of clutter, clean, well swept, and well lit. Clean spills up immediately. Floor areas should be level and non-slip. Good housekeeping practices and workplace design will reduce the number of injuries and accidents from slips, trips, and falls.
- ✓ Do not wear loose clothing, work gloves, neckties, rings, bracelets or other jewellery that can become entangled with moving parts. Confine long hair.
- ✓ Avoid awkward operations and hand positions where a sudden slip could cause your hand to move into the cutting tool or blade.
- ✓ Do not remove sawdust or cuttings from the cutting head by hand while a machine is running. Use a stick or brush when the machine has stopped moving.
- ✓ Do not use compressed air to remove sawdust, turnings, etc. from machines or clothing.
- ✓ Do not leave machines running unattended (unless they are designed and intended to be operated while unattended). Do not leave a machine until the power off is turned off and the machine comes to a complete stop.

2.2 ADDITIONAL SAFETY FOR PLANER THICKNESSERS

DO NOT use this machine unless you have been instructed in its safe use and operation and have read the instruction manual.



Eye and Ear protection must be worn at all times in work areas.



Long and loose hair should always be contained.



Appropriate footwear that have substantial uppers must be worn.



Close fitting/protective clothing must be worn.



Rings and jewellery must not be worn.



Dust mask protection must be worn when using this machine.

PRE-OPERATIONAL SAFETY CHECKS

1. Check workspaces are clear and no slip/trip-hazards are present.
2. Check safety guards are adjusted and operate to give maximum protection.
3. Where a bridge guard is fitted adjust the guard to ensure a maximum of 2mm clearance between guard and the timber.
4. Do not plane stock with structural defects.
5. Locate and ensure you are familiar with the operation of the ON/OFF starter and E-Stop (if fitted).
6. Set depth of cut and lock table. Never make a single cut greater than 2mm.
7. Check and lock fence in position.
8. Start the dust extraction unit before using the machine.

OPERATIONAL SAFETY CHECKS

1. Hands must not be closer than 100mm from the cutter head when it is rotating.
2. Use push blocks wherever possible.
3. Never leave the machine while it is running.
4. Place cupped boards with the concave side against the table.
5. Plane with the grain. Hold the workpiece firmly and apply even feed rate.
6. Operator should stand to side of infeed table to avoid possible kickbacks.
7. Before making any adjustments switch off and wait for the cutter head to completely stop.

HOUSEKEEPING

1. Switch off and reset all guards to a fully closed position after use.
2. Reset the depth of cut to zero after use.
3. Leave the machine in a safe, clean and tidy state.

DON'T

- Do not surface stock less than 300mm long x 20mm wide x 15mm thick
- Rebating at the end of the cutter-block
- Planing end grain

2.2 ADDITIONAL SAFETY FOR PLANER THICKNESSERS CONT.

Most machines currently, are well interlocked to ensure that the machine must be in the correct configuration to perform one task or the other. Make yourself familiar with these configurations and do not try to use the machine in a half and half state; or rig the interlocks to enable you to do so. These machines are designed for cutting timber only. They will, but are not designed to, cut timber derivatives or composites. Glue lines in plywood, block board etc, will 'notch' blades. The bonding agent in chipboard is likewise detrimental to the health of your planer cutters.

Overhand Planing

Make sure during overhand planing operations, that the fence is set to the required angle, is securely fastened and locked in position. Ensure the planer block guarding is in position and secured.

- Disengage the autofeed for the thicknesser.
- Ensure both tables are correctly seated and locked down.
- Ensure the dust extraction hood is in place and is not blocked.
- Fit dust extraction.

Thicknessing

When thicknessing, remove the fence and place the assembly in a safe place.

Lower the thicknessing table slightly. Unlock and swing both tables 'up and out of the way'; taking care not to foul the overhand guard/arm assembly, which will should swing free. Turn the dust extraction hood up and over the block.

- Connect the dust extraction. Ensure the hose will not foul any material being passed through the machine.
- Check the height of the thicknessing table.
- Engage the autofeed mechanism.
- Periodically, clean any excess build up of resin from the thicknessing table, and apply any proprietary brand of lubricating agent.

Check the sharpness of cutters, check for 'nicks' and 'notches', if there are damaged sections on the cutters, try to machine in the 'clear' areas or replace the cutters. This is very important when planing material down to 'thin' dimensions. Always maintain pressure on the 'front' of the material i.e., that portion of the material that has passed over the cutter block. Use a push stick or a pusher shoe to clear the end of the workpiece over the cutter block.



2.2 ADDITIONAL SAFETY FOR PLANER THICKNESSERS CONT.

Some workpieces are not safe to plane or may require modification before they are safe to pass through the planer. Before cutting, inspect all workpieces for the following:

- **Material Type:** This machine is only intended for planing workpieces of natural wood. Attempting to plane workpieces of any other material, including wood composites, could lead to serious personal injury and property damage.
- **Foreign Objects:** Inspect lumber for defects and foreign objects (nails, staples, imbedded gravel, etc.). If you have any question about the quality of your lumber, DO NOT use it. Remember, wood stacked on a concrete floor can have small pieces of stone or concrete pressed into the surface.
- **Large/Loose Knots:** Loose knots can become dislodged during the planing operation. Large knots can cause kickback and machine damage. Always choose workpieces that do not have large/loose knots when planing.
- **Wet or "Green" Stock:** Avoid planing wood with a high water content. Wood with more than 20% moisture content or wood exposed to excessive moisture (such as rain or snow), will plane poorly and cause excessive wear to the cutterhead and motor. Excess moisture can also hasten rust and corrosion of the planer and/or individual components.
- **Excessive Warping:** Workpieces with excessive cupping, bowing, or twisting are dangerous to cut because they are unstable and often unpredictable when being planed. DO NOT use workpieces with these characteristics!
- **Minor Cupping:** Workpieces with slight cupping can be safely supported if the cupped side is facing the planer table. On the contrary, a workpiece supported on the bowed side will rock during planing and could cause severe injury from kickback.
- **Use the full width of the planer.** Alternate the cutting path between the left, the right and the middle of the table to evenly distribute the wear across all inserts.
- **Remove excess glue:** Scrape all glue off of joined boards before planing.
- **Plane the workpiece with the grain.** NEVER feed end-cut or end-grained lumber into your planer.
- **Plane both faces:** When possible, plane both faces of the workpiece so that they will be parallel with one another.

2.3 LIFTING AND PLACEMENT

On the day that the machine arrives, make sure that a fork lift with sufficient capacity is available to unload the machine from the vehicle. Ensure access to the chosen site is clear and that doors and ceilings are sufficiently high and wide enough to receive the machine.

Work out which way the machine is to face and move it to its desired position in the workshop. Make sure it is positioned on a flat level surface and ensure that the machine is positioned to allow sufficient clearance both in front and behind the machine to cater for the maximum length of timber you will wish to machine.

NOTE: Remember to allow sufficient space around the machine to allow for your stance when overhand planing and moving from end to end of the machine if you are thicknessing single handed. Remember that when the surface tables are up and out of the way' for thicknessing, the machine is appreciably wider than when it is in overhand mode.

2.4 ELECTRICAL INSTALLATION

Place the machine near an existing power source. Make sure all power cords are protected from traffic, material handling, moisture, chemicals, or other hazards. Make sure there is access to a means of disconnecting the power source. The electrical circuit must meet the requirements for 240V. To minimize the risk of electrocution, fire, or equipment damage, these machines may be hard wired with installation work and electrical wiring done by a qualified electrician.

NOTE : The use of an extension cord is not recommended as it may decrease the life of electrical components on your machine.

ELECTRICAL REQUIREMENTS

Nominal Voltage.....	240V
Cycle.....	50 Hz
Phase.....	Single Phase
Power Supply Circuit.....	15 Amps
Full Load Current (PT-254S).....	9.5 Amps
Full Load Current (PT-305S).....	13.5 Amps

(Full load current rating is also on the specification plate on the motor.)

2.5 FULL-LOAD CURRENT RATING

The full-load current rating is the amperage a machine draws when running at 100% of the output power. Where machines have more than one motor, the full load current is the amperage drawn by the largest motor or a total of all the motors and electrical devices that might operate at one time during normal operations.

Full-Load Current Rating for PT-254S at 240V is 9.5 Amps.

Full-Load Current Rating for PT-305S at 240V is 13.5 Amps.

It should be noted that the full-load current is not the maximum amount of amps that the machine will draw. If the machine is overloaded, it will draw additional amps beyond the full-load rating and if the machine is overloaded for a long period of time, damage, overheating, or fire may be caused to the motor and circuitry.

This is especially true if connected to an undersized circuit or a long extension lead. To reduce the risk of these hazards, avoid overloading the machine during operation and make sure it is connected to a power supply circuit that meets the requirements.



3. SETUP

3.1 ASSEMBLY

The Planer Thicknesser comes 95% assembled. It is enclosed in a packing case, on a pallet, with all the accessories. (Fig. 3.1).

1. Having removed the top and the sides of the packing case, remove all the loose components from the machine.

2. The machine is secured down on to the pallet that forms the bottom of the packing case. Remove the 'hold down' brackets, (Fig.3.2). Place lifting straps around the machine, DO NOT lift, push or pull the machine using the tables. Any movement is best carried out against the main frame cabinet. Hoist the machine clear of the pallet, slide the pallet out of the way and lower the machine in position.

NOTE: *There are four 10mm threaded holes located under the main frame, to attach adjustable machine feet if required. Machine mounts make it easy to adjust the leveling of the machine and also reduce vibration transferred from other machines close by.*



ORDER CODE M001



FIG. 3.1

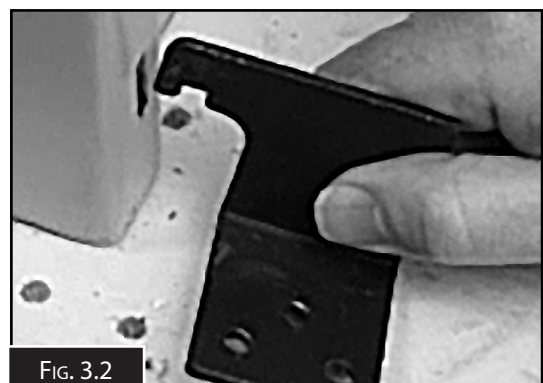

FIG. 3.2

EMERGENCY STOP LEVER ASSEMBLY

Locate the RED emergency stop lever (A) and remove the two Phillips screws and nuts. Line up the holes in the stop lever with the holes on the switch housing, insert the Phillips screws through the hinges and replace the nuts. Lightly tighten sufficiently to allow the lever to move freely. (Fig. 3.3)

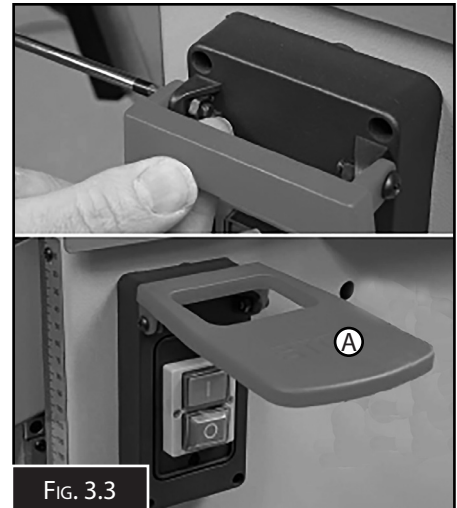

FIG. 3.3

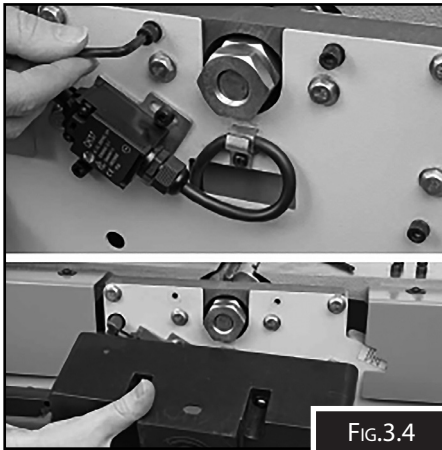

FIG.3.4

CUTTER BLOCK SIDE GUARD

Remove the four Hex screws and washers on the front of the planer thicknesser and place the side guard up against the frame covering the micro switch and cutter block drive shaft. Line up the holes in the guard with the threaded holes in the frame and secure using the Hex screws and washers removed earlier. (Fig.3.4)

OVERHEAD CUTTER GUARD MOUNTING ARM

Locate the overhead cutter mounting arm and remove the lock nut from the threaded bolt. Screw the long threaded knob all the way through the existing threaded hole in the outfeed table, (Fig. 3.5) then fit the locknut.

Do not screw the locknut all the way up, but just enough so the bolt end sticks out 2 or 3 mm. (Fig.3.6) For safety, this allows the knob to be undone and the guard to be swiveled up out of the way and then lock back in place to lift table.

Locate the cutter block guard. Loosen the locking knob on top of the mounting plate holder on the mounting arm. Slot the cutter block guard through the mounting plate and tighten the locking knob. (Fig.3.7)

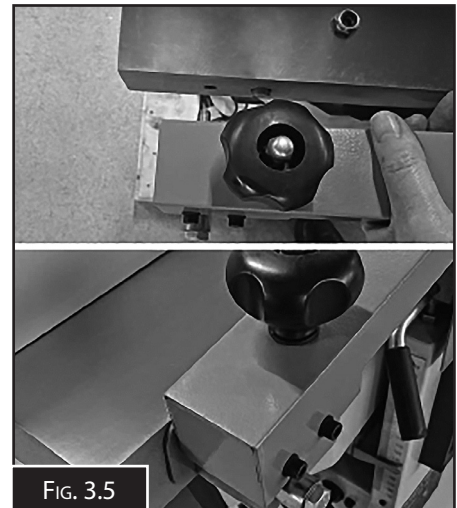

FIG. 3.5

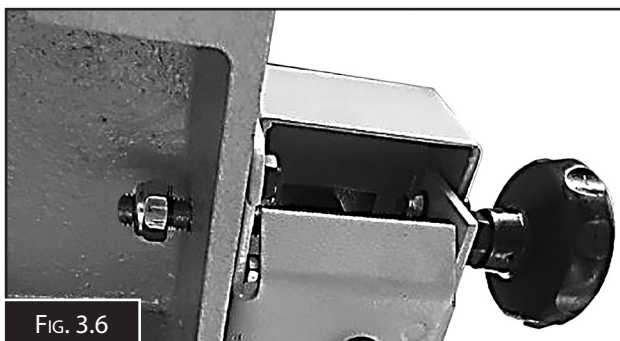

FIG. 3.6

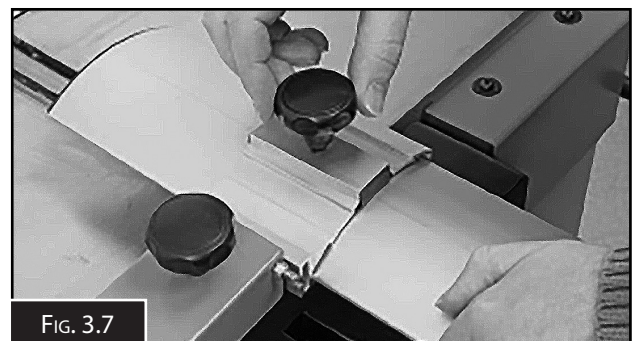

FIG. 3.7

TABLE LIFTING HANDLES (PT-305S ONLY)

Two handles have been supplied to assist in the lifting and lowering of the in feed and outfeed table when setting up between planer and thicknesser mode. (Fig.3.8)

The large handle goes on the left-hand side on the outfeed table under the cutter guard swivel bracket.

The small handle goes on the right hand on the infeed table

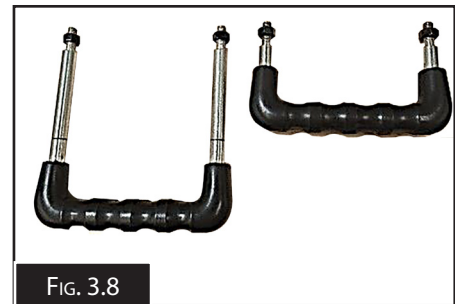

FIG. 3.8

MOUNTING THE FENCE

To mount the fence assembly find the fence tilt assembly, fence mounting bracket with cap head screws and the two lift and shift handles.

To mount the fence

1. Line up the mounting bracket pre-drilled holes with the threaded holes in the table to the rear of planer thicknesser and secure using the two cap head screws. (Fig.3.9)
2. Loosen the clamping handle on the mounting bracket, insert the tilt assembly base plate through the mounting bracket sufficiently for the next step. Lightly tighten clamping handle,

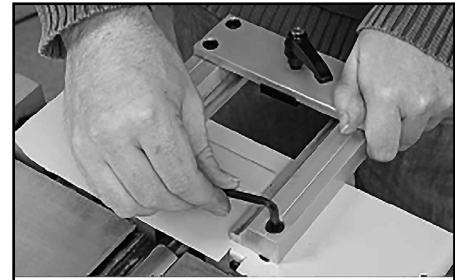

FIG. 3.9

NOTE: Make sure the fence is the right way up with the machined cutout for the cutter block flush against the tables.

4. Insert the thread of one of the lift and shift handles through the elongated slot and screw it into the fence mounting plate. (Fig.3.10)



FIG. 3.10

NOTE: As space is limited to the rear of the tilt assembly housing it may be easier to remove the handle from the threaded bolt, to make it easier to screw in. (Fig.3.10)

5. Replace the handle and screw including the spring. (Fig.3.11) and secure in place with a Phillips screwdriver Repeat for the second handle clamp.
6. Slide the fence until it's stop is up against the tilt assembly housing then tighten the lift and shift handles.



FIG. 3.11

3.2 SETTING SURFACE TABLES AND CUTTER BLOCK

The correct setting of the tables and the cutter block is important, not only to improve the quality of the work, but also to the safety when operating the machine

SETTING THE FENCE AT 90°

Using a 90° engineers square, place it on the outfeed table and against the fence, checking the fence is square with the outfeed table. If adjustment is required then loosen the tilt clamping handle at the rear of the fence assembly and adjust the fence until correct, re-tighten the clamping handle. (Fig.3.12)

NOTE: Check that the pointer on the tilt assembly lines up with 'zero' on the scale. If, not loosen the pointer's clamping screw and adjust until correct. (Fig.3.12)

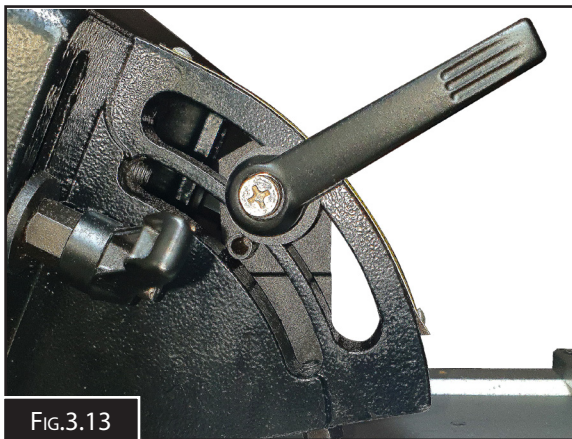

FIG.3.13

SETTING THE 90° FENCE STOP

The fence adjustment mechanism is fitted with a 90° dead stop for the quick and accurate setting at 90°. The stop is set before the machine leaves the factory but may at times need to be reset. (Fig.3.13)

To adjust the 90° dead stop

1. Carry out the procedure "Setting The Fence At 90°" as above.
2. Loosen the locknut ("A" in Fig.3.14)
3. Adjust the stop screw ("B" in Fig.3.14) until it is hard up against the dead stop ("C" in Fig.3.14)
4. Tighten the lock nut.
5. Move the fence away from the stop and return to check the adjustment to make sure it is correct.

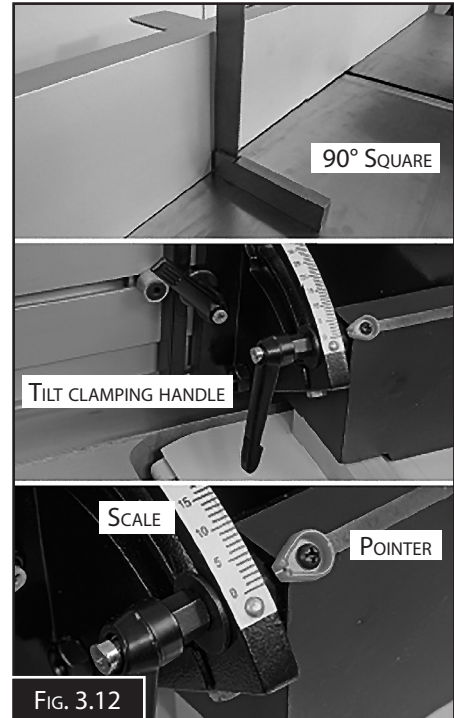

FIG. 3.12

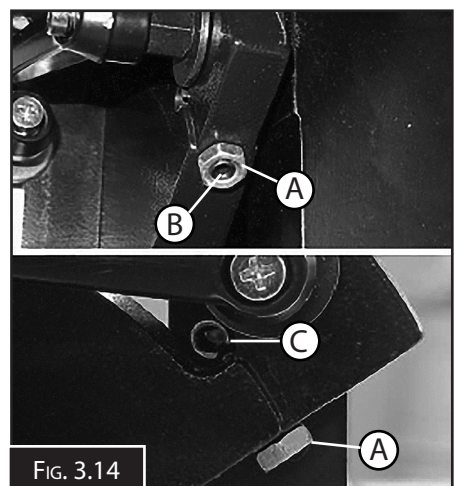

FIG. 3.14

SETTING THE 45° FENCE STOP

The setting of the 45° fence stop needs to be done in two steps.

To set the 45° Fence Stop:

1. Set the fence to 45° degrees by loosening the tilt clamping handle as before, place a mitre square up against the fence and check the angle with the outfeed table. Adjust the fence until correct and nip up the tilt clamping handle. Check that the pointer is at the 45 degree mark on the scale and the fence mechanism is against the 45° dead stop. (Fig.3.15)
2. If the dead stop prevents the fence from being set at 45° or if when it is set at 45° there is a gap between the stop and the stop screw then the following needs to be done.
3. With the fence mechanism clamped at 45° re move the fence to access the stop screw. ("A" in Fig.3.15)
4. Adjust the screw until it is up against the stop.
5. Replace the fence, and check the angle again.
6. Repeat the steps until correct.

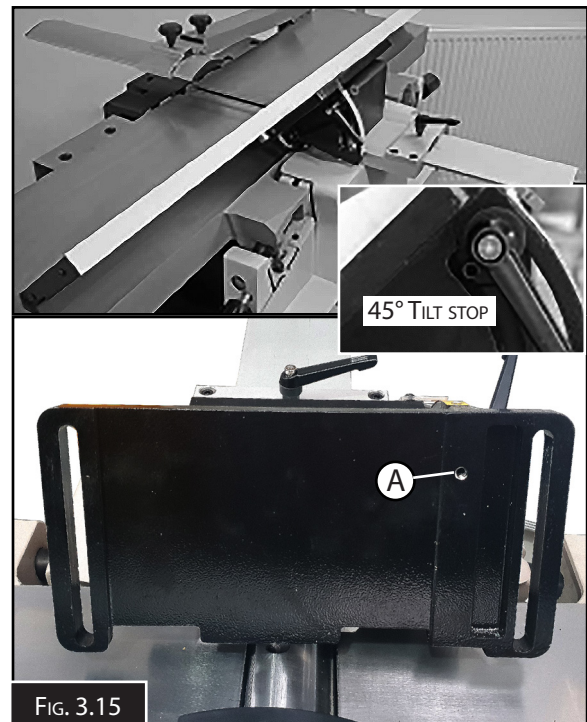

FIG. 3.15

3.3 SETTING THE OUTFEED SURFACE TABLE

The outfeed table must be level with the cutter block inserts or blades when they are at top-dead-center. This adjustment has been made at the factory but should be checked again before operating the Thicknesser Planer. This adjustment will also have to be made any time you perform maintenance on the cutter block.

⚠ WARNING

Before attempting the adjustment, the machine must be disconnected from the power supply.

Once the machine has been positioned where it will be used, remove the fence and open and close the "outfeed" table. Locking it in place. Open the in-feed table and leave up out of the way. Remove the black plastic guard off the front side of machine that covers the spindle end. This will allow the service operator to easily turn the spindle by hand using the nut on the end of the spindle.

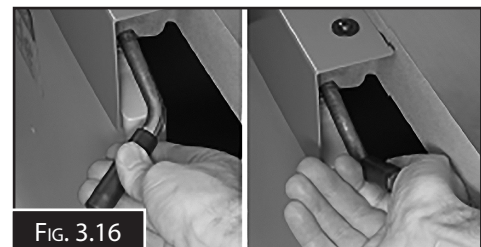

FIG. 3.16

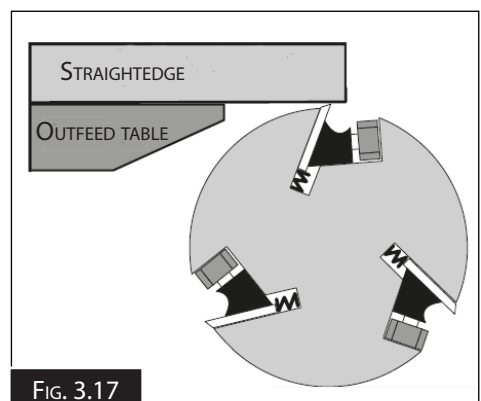

FIG. 3.17

3.3 SETTING THE OUTFEED SURFACE TABLE

With a steel straightedge (A small steel ruler is good) Sit the straight edge on the middle of the table as shown above one of the blades. (Fig. 3.18) Pressing down lightly on the straightedge carefully turn the spindle by hand noting how far it lifts up the straightedge and pulls it along before it stops moving it. A good amount is 2mm to 4 mm this means cutter is approximately 0.1mm above the table.

To set the outfeed table height:

1. DISCONNECT THE MACHINE FROM THE POWER SUPPLY
2. Remove the fence assembly and place the unit in a safe place where damage is minimized. Unlock the infeed table locking handle (Fig.3.16) and raise the table up out of the way
3. Place a straightedge on the outfeed table so it extends over the cutterhead. (Fig.3.17)
4. Rotate the cutterhead pulley until the steel rule moves 2-4mm.



FIG. 3.18

If adjustment is required, then the top position Stop Nut on the table depth screw will need repositioning.

NOTE: To ensure the table remains flat, when adjustments are made the table lock lever must be undone.

5. Undo table lock lever and back off the table by turning the hand wheel anticlockwise.
6. Undo the grub screw on the side of the position stop nut and rotate the nut on the thread as needed. (Anticlockwise moves table up, Clockwise moves table down)
7. Tightened the grub screw, wind the table down and up until the table reaches the position top stop.
8. Lock the table.
9. Check the table to cutter distance with the straightedge and adjust if needed until the required 2 to 4mm movement is achieved.
10. Replace the black plastic guard that covers the spindle end onto the front of the machine.
11. The Infeed table must be checked to ensure its top stop aligns the infeed table with the outfeed table.



FIG. 3.18A

3.4 SETTING THE INFEEED SURFACE TABLE

With the outfeed table now set all the way up on its adjustment and locked down. Carefully Drop down the infeed table and wind its height adjustment hand wheel down a few turns and then all the way up to its stop. Now lock the infeed table lock lever. With a steel straightedge, holding it down on the outfeed table, slide the straightedge from the outfeed table over the cutter head (not touching the blade) to the infeed table. (Fig. 3.19)

NOTE: The outfeed table must be set first

1. DISCONNECT THE MACHINE FROM THE POWER SUPPLY
2. Raise the infeed table by turning the rise and fall adjusting knob, (Fig.3.20) until the infeed table top stop is reached. The pointer should read 'zero' on the scale.
3. Place a straight edge across both tables and check they are both level. If not, then the position stop nut, will need to be adjusted.
4. Remove the fence assembly. Unlock the infeed table locking handle and raise the table up. Undo the grub screw on the side of the position stop nut and rotate the nut on the thread as needed. (Anticlockwise moves table up, Clockwise moves table down) (Fig. 3.20)
5. While holding the table, pull out the table locking bar (Fig.3.16) and lower the outfeed table, securing in place with the locking handle. Place the straight edge across the tables and check again. Repeat the procedure until both surface tables are level.

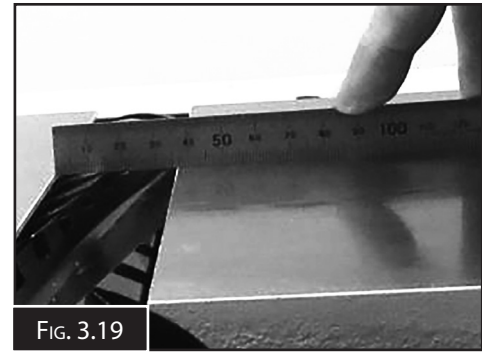

FIG. 3.19

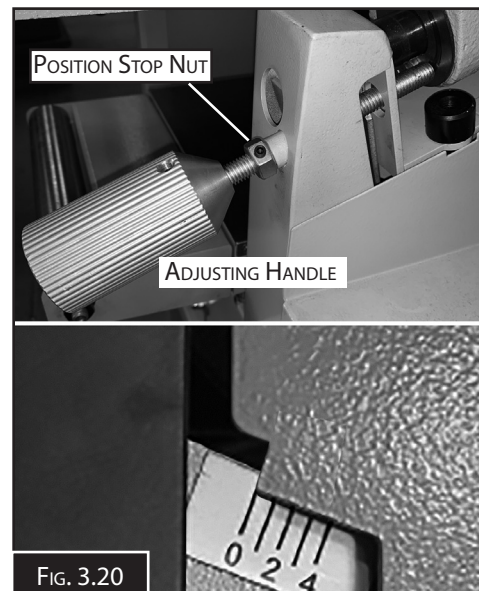

FIG. 3.20

3.5 SETTING THE THICKNESSING TABLE STOP

1. Raise the planing tables as explained in the previous section.
2. Release the rise and fall clamping handle ("A" in Fig.3.21) and turn the operating wheel ("B" in Fig.3.21) counter clockwise to lower the thicknessing table until the pointer reads 190 on the PT-254S scale or 225 on the PT-305S and check that the stop is up against the underside of the thicknessing table. If not, loosen the locking nut and adjust the stop then re-tighten the nut to lock the setting. (Fig.3.22)

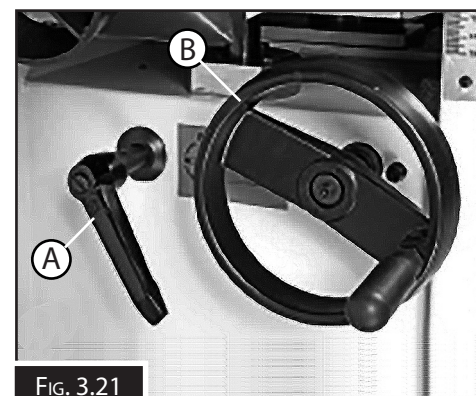

FIG. 3.21

SETTING THE THICKNESSING TABLE STOP Cont.

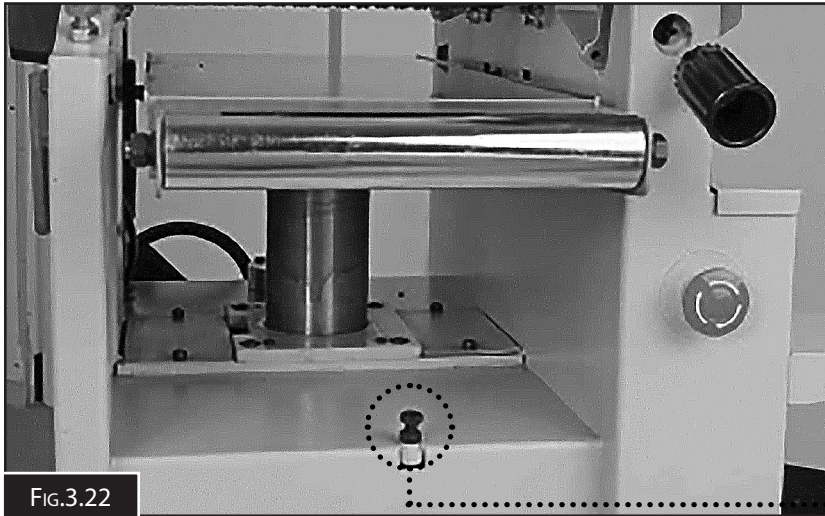

FIG.3.22



3.6 SETTING THE THICKNESSING TABLE EXTENSION

To produce an quality finish it is important that the table extension are setup correctly and in line with the main thickeninging table.

To set up the table extensions,

1. Place a straight edge across the thickeninging table and guide roller and check they are both in line with each other. (Fig.3.23)
2. If adjustment is required, loosen the two cap head bolts (A) and adjust the Hex bolts (B) until alignment is reached, tighten the nuts (C) to lock the setting. Re-tighten the cap head bolts (A), (Fig.3.23)

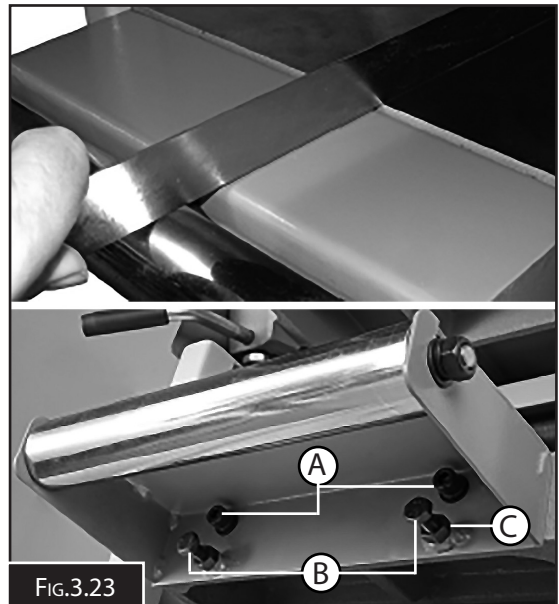

FIG.3.23

4. OPERATING INSTRUCTIONS

4.1 SETTING THE MACHINE FOR PLANING

1. Lower the surface tables and re-mount the fence assembly. Check the machine is set up correctly, see the section for setting up the machine. Press down the locking lever to engage the planing function. (Fig.4.1)
2. Read the section on safety for Thicknesser Planer for the correct safe operating procedures (Pages 14, 15 & 16)

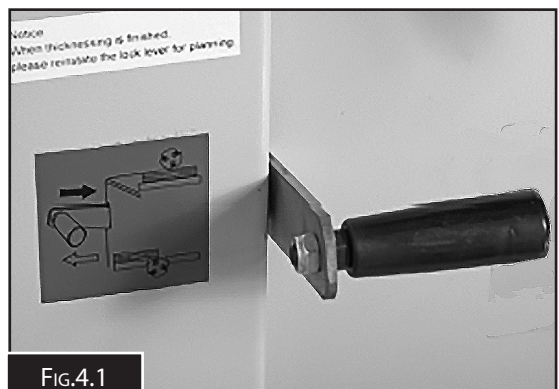

FIG.4.1

3. Lift up the emergency stop shroud lever and press the 'GREEN' button to start the machine.
4. When planing is finished switch off the machine by pressing the 'RED' button and wait until it comes to a complete stop.

4.2 SETTING THE MACHINE FOR THICKENING

1. Remove the fence assembly. Unlock the surface table and raise them to the upright position. (Fig.4.2)
2. Rotate the dust extraction hood until it's in the correct position. (Fig.4.3)
3. Raise the locking lever to engage the thickening function. (Fig.4.1)
4. Connect a 100mm extraction hose to the extraction hood outlet.
5. Read the section on safety for Thicknesser Planer for the correct safe operating procedures (Pages 14, 15 & 16)
6. Release the rise and fall clamping handle (A) and turn the operating wheel (B) clockwise to raise the thickening table to the required thickness then re-tighten the clamping handle. (Fig.4.4).
7. Lift up the emergency stop shroud lever and press the 'GREEN' button to start the machine.
8. When thickening is finished switch off the machine by pressing the 'RED' button and wait until it comes to a complete stop.

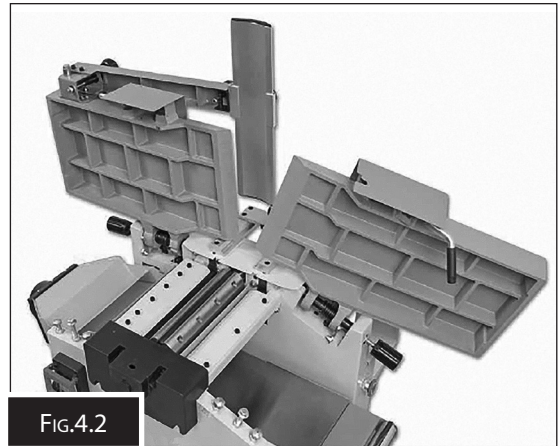

FIG.4.2

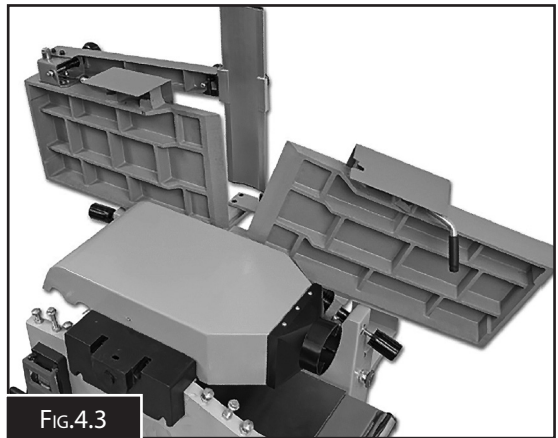

FIG.4.3



FIG. 4.4

4.3 EMERGENCY STOP

There are two emergency stops on these machines, the first is part of the switch assembly,

PT-254S - large red shroud lever covering the ON/OFF buttons. (See Page 6)

PT-305S - mushroom shaped button. (See Page 7)

The second is mushroom shaped, mounted to the side of the machine. (Fig.4.5)

NOTE:

To restart the machine, twist the mushroom shaped top to unlock it and allow it to pop up.

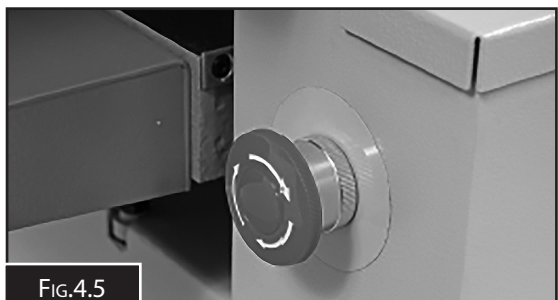

FIG.4.5

4.4 TROUBLESHOOTING

Should any problems arise review the troubleshooting procedures in this section to find the possible problem or fix and adjust your machine.

For spare parts view the procedure for ordering as layed out on the first page of spare parts section.

SYMPTOM	POSSIBLE CAUSE	POSSIBLE SOLUTION
Machine does not start or a breaker trips.	<ol style="list-style-type: none"> 1. Stop push-button engaged/faulty. 2. Power switched OFF or at fault. 3. Thermal overload relay has tripped. 4. Wall circuit breaker tripped. 5. Plug/receptacle at fault/wired incorrectly. 6. Motor connection wired incorrectly. 7. Contactor not energized. 8. Wiring open/has high resistance. 9. ON/OFF switch at fault. 10. Start capacitor at fault. 11. Centrifugal switch at fault 12. Motor at fault. 	<ol style="list-style-type: none"> 1. Check magnetic switch/replace it. 2. Ensure power supply is switched ON 3. Reset trip load dial if necessary; replace. 4. Ensure circuit size is correct/replace. 5. Test for good contacts; correct the wiring. 6. Correct motor wiring connections 7. Test all legs for power/replace if faulty. 8. Check and fix broken, disconnected wires 9. Replace switch. 10. Test/replace if faulty. 11. Adjust/replace centrifugal switch. 12. Test/repair/replace.
Machine stalls or is underpowered	<ol style="list-style-type: none"> 1. Feed rate too fast. 2. Workpiece material not suitable. 3. Dust collection ducting problem. 4. Motor overheated. 5. V-belt(s) slipping. 6. Run capacitor at fault. 7. Pulley/sprocket slipping on shaft. 8. Motor bearings at fault. 9. Motor at fault. 	<ol style="list-style-type: none"> 1. Decrease feed rate. 2. Ensure timber moisture is below 20%. 3. Clear blockages, use smooth wall duct, 4. Clean motor, let cool, and reduce load. 5. Tension/replace belt(s) ensure pulleys are aligned 6. Test/repair/replace. 7. Replace loose pulley/shaft. 8. Test/repair/replace. 9. Test/repair/replace.
Excessive step (snipe) (gouge at the end of the workpiece that is uneven with the rest of the cut).	<ol style="list-style-type: none"> 1. Rear table extension slopes down or is not level with the table 2. Workpiece is not fully supported as it leaves the thicknesser. 	<ol style="list-style-type: none"> 1. Adjust the rear extension wing set screws to make the extension level with the table 2. Use a roller stands to properly support the workpiece as it leaves the thicknesser.
Workpiece stops/slow in the middle of the cut.	<ol style="list-style-type: none"> 1. Depth of cut too deep. 2. Pitch/glue build-up on thicknesser components. 3. Feed rollers set too low or too high. 	<ol style="list-style-type: none"> 1. Reduce the depth of cut. 2. Clean planer components with a pitch/resin dissolving solvent. 3. Adjust the feed rollers to the correct height

5.2 TROUBLESHOOTING CONT.

SYMPTOM	POSSIBLE CAUSE	POSSIBLE SOLUTION
Machine has vibration or noisy operation.	<ol style="list-style-type: none"> 1. Belt slaps the cover. 2. V-belt worn or loose. 3. Pulley loose. 4. Motor mount loose/broken. 5. Motor fan rubbing on fan cover. 6. Motor bearings at fault. 7. Cutterhead bearings at fault. 8. Chip deflector hitting cutterhead. 	<ol style="list-style-type: none"> 1. Replace/realign belt. 2. Inspect/replace belt with a new belt.. 3. Realign/replace shaft, pulley, setscrew, & key. 4. Tighten/replace. 5. Fix/replace fan cover; replace damaged fan. 5. Test by rotating shaft; & replace worn bearings 7. Replace bearing(s)/realign cutterhead. 8. Check/replace chip deflector and realign
Consistent chipping pattern.	<ol style="list-style-type: none"> 1. Knots or conflicting grain direction in workpiece. 2. Nicked or chipped cutter or insert. 3. Feed rate too fast. 4. Depth of cut too deep. 	<ol style="list-style-type: none"> 1. Inspect workpiece for knots and grain direction; use only clean stock. 2. Rotate/replace cutters or insert . 3. Reduce feed rate. 4. Reduce the depth of cut.
Furry grain.	<ol style="list-style-type: none"> 1. Workpiece has high moisture content or surface wetness. 2. Dull cutter blades or inserts 	<ol style="list-style-type: none"> 1. Allow workpiece to dry if moisture content is over 20% or has surface wetness. 2. Rotate/replace cutter blades or inserts
Lines or ridges running the length of the workpiece	<ol style="list-style-type: none"> 1. Nicked blades or chipped inserts. 	<ol style="list-style-type: none"> 1. Rotate or replace the inserts or replace the damaged blades.
Uneven cutting marks, wavy surface, or chatter marks on the workpiece.	<ol style="list-style-type: none"> 1. Feed rate too fast. 2. Insert(s) or blades not properly installed. 3. Worn cutterhead bearings. 	<ol style="list-style-type: none"> 1. Reduce feed rate. 2. Remove insert(s) or blades, then properly clean and install 3. Replace cutterhead bearings
Glassy surface	<ol style="list-style-type: none"> 1. Inserts are dull. 2. Feed rate too slow. 3. Depth of cut too shallow 	<ol style="list-style-type: none"> 1. Rotate/replace inserts or replace blades 2. Increase feed rate 3. Increase depth of cut
Inconsistent chip marks.	<ol style="list-style-type: none"> 1. Chips are not being removed from around the cutterhead 	<ol style="list-style-type: none"> 1. Use an adequate dust collection system; adjust the chip deflector in or out.

5. MAINTENANCE

5.1 CHANGING THE CUTTER BLOCK BLADES

The planer blades are mounted into three slot housings machined in the cutter block. The slot housing comprises of a slot cut on a radial axis with a reverse tapered slot around it. The depth of the first slot governs the seating of the blade holder, the second slot allows the blade to be set to its correct depth in the block.

The blade holder is machined with a tapered face set at the same angle as the slot. This allows the blade to be clamped between parallel faces, as in (Fig.5.1).

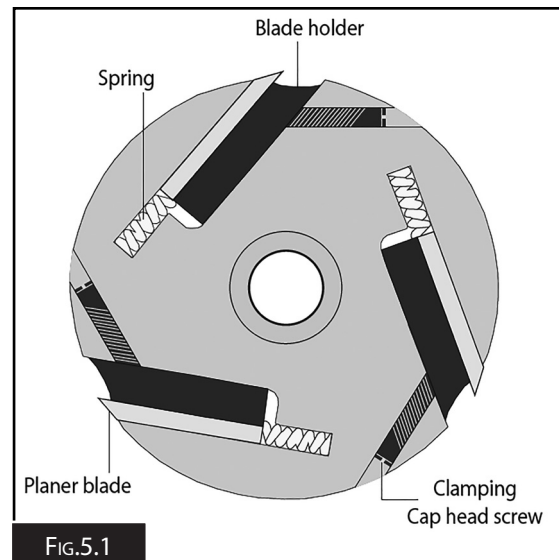

To Change the Standard Blades

1. DISCONNECT THE MACHINE FROM THE POWER SUPPLY
2. Remove the fence assembly, and raise the two surface tables to gain access to the cutter block,
3. Turn the cutter block until one of the slots is in the upright position. Using a 4mm Hex key loosen the four cap head screws on the cutter block, removing the clamping effect. This should allow the blade to 'spring' up, protruding clear of the edge of the cutter block. (Fig.5.2)

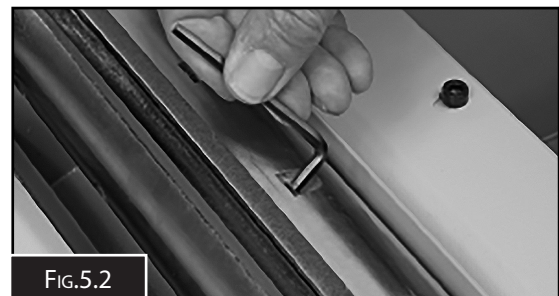

4. Carefully remove the blade and place safely aside

NOTE: Be very careful when removing the blade as they are extremely sharp.

5. Remove the blade holder and lay aside. Clean the slot housing thoroughly, remove any resin build-up, sawdust, chips etc. Clean the blade holder in the cutter block.
6. Place the new blade in front of the blade holder. Carefully position the blade and the holder to line up with the edge of the cutter block. Press the blade setting tool gently down onto the blade, ensuring the locating feet are firmly seated against the cutter block and the blade is against the setting recess. (Fig.5.3)
7. Hold the blade and setting tool (L) in position, and tighten two cap head screws to provide a firm clamp on the blade. Tighten the remaining cap head screws.

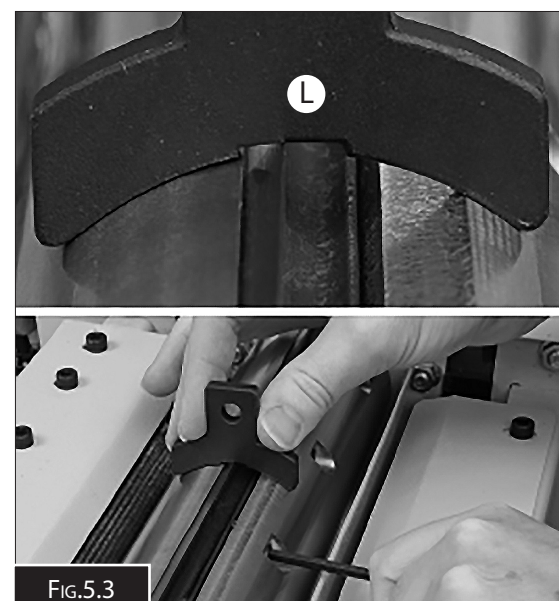

5.2 SPIRAL CUTTER BLOCKS

Some models are supplied with a spiral cutterhead equipped with indexable carbide inserts. As they wear they can be rotated to one of their four cutting edges. There is 44 square cutters in total on the 10inch model (PT-254S) and 56 cutters on the 12inch model (PT-305S). (Fig. 5.4)

If one edge of the insert becomes dull or damaged, simply rotate it 90° to reveal a fresh cutting edge. (Fig. 5.5)

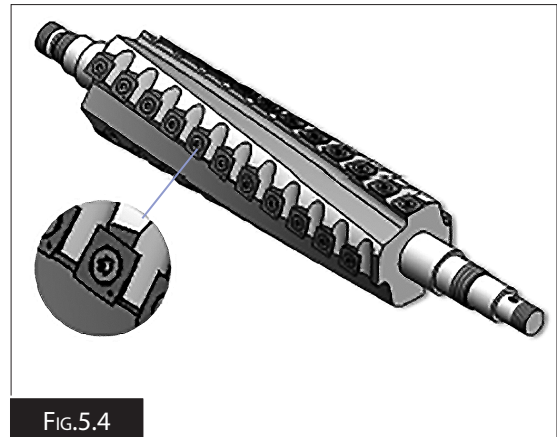

FIG.5.4

To change or rotate a spiral cutterhead inserts:

1. DISCONNECT THE MACHINE FROM THE POWER!
2. Remove the fence assembly, and raise the two surface tables to gain access to the cutter block,
3. Leather heavy gloves should be worn to protect your hands and fingers.
4. Remove any sawdust or debris from around the insert, Torx screw, and the surrounding area.
5. Remove the Torx screw and the insert, then clean both parts and the pocket where the insert sits.

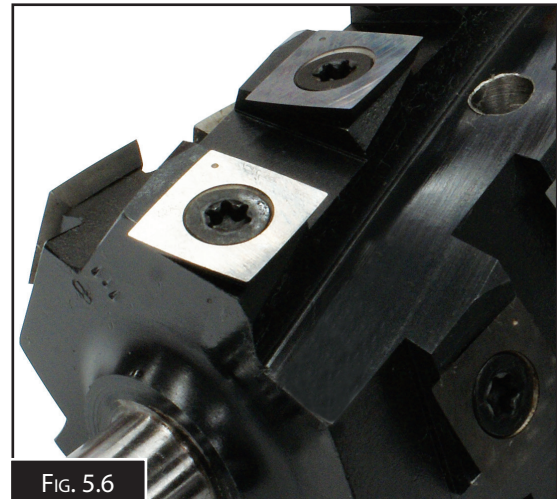

FIG. 5.6

Note: *If an insert is to be rotated the all inserts should be rotated. This is critical to achieving a smooth and precision finish. Ensure the cutter head pocket have been thoroughly cleaned*

If dirt or dust is trapped between the insert and cutterhead it will slightly raise the insert, and make noticeable marks.

6. Rotate the insert so that a fresh cutting edge faces outward. If all four insert cutting edges have been used, replace the insert with a new one. Always position the reference mark (Fig.5.5) on the insert in the same position when installing a new insert to aid in the rotational sequencing.
7. Lubricate the Torx screw threads with a very small amount of light machine oil, wipe the excess off, and tighten the screws making sure not to over tighten them.

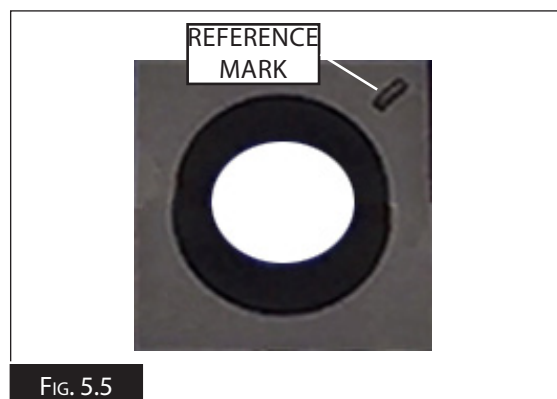

FIG. 5.5

NOTE:
Do Not overtightened to avoid the torx head screw from being damaged.

Note: *Do Not use too much oil. The excess may squeeze out of the threaded hole as you install the insert and force the insert to raise slightly, forcing the insert out of alignment.*

5.3 MAINTENANCE SCHEDULE

Daily

Check the overhand tables and the thickening table are clean, and not coated with resin etc. Apply a cleaner/lubricating agent to all the tables.

Check the blades for sharpness and damage.



FIG. 5.7

Check the cable and plug for damage. Mount the planer fence and check it is set correctly

Check the dust extraction hood and ensure there are no excessive build up of sawdust/resin, especially in the mouth of the chip deflector and around the mouth of the extractor. (Fig.5.7)

Check the rollers of the thickening table rotate freely, and there is no build up between the roller and the extension table.

Weekly

Carry out the 'Daily' checks.

Clean the machine thoroughly, remove any shavings, sawdust, chips etc, from in, under and around the machine.

Check the cutter block for resin build up, especially behind the blade and in the scallop of the blade holder.

Raise the tables and brush out and clean any debris or build up around the area of the slots in the edges of the overhand tables.

Check the infeed and take off pressure rollers are not clogged, clean as necessary.

Check the action of the anti-kickback fingers, again clean and lubricate as required.

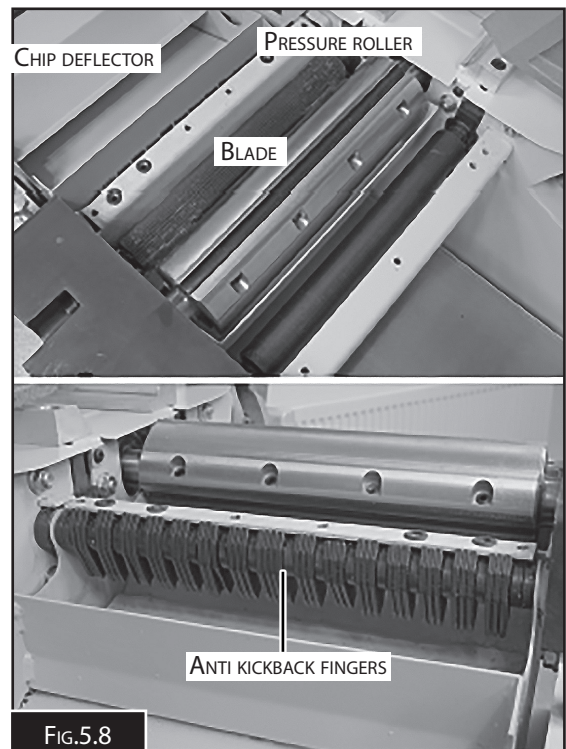

FIG.5.8

Monthly

Carry out the 'Weekly' checks.

Remove the upper and lower machine cover plates, check the condition and tension of the drive belt.

Check the autofeed engage and disengage function.

5.4 ADJUSTING BELT AND CHAIN DRIVE.

The cogged V-belt transfers power from the motor to the cutter-head, and then to the infeed and outfeed rollers through the drive-chains. To ensure efficient transfer of power to these systems, make sure the cogged V-belt is always properly tensioned and in good condition.

If the cogged V-belt is worn, cracked, or damaged, replace it with a new belt.

To adjust the cogged V-belt

1. DISCONNECT THE MACHINE FROM THE POWER
2. Raise the infeed and outfeed surface tables to gain access to the top cover screws.
3. Remove the top cover to expose the top of the drive mechanism. (Fig.5.9)
4. Remove the bottom cover to gain access to the bottom of the drive mechanism. (Fig.5.10)
5. Loosen the four domed nuts securing the motor and let the motor slide down to find its own level then re-tighten the domed nuts to secure the motor in position. (Fig.5.12)
6. Check the tension of the cogged V-belt by pressing the belt. It should have only approximately 10 mm of movement.
7. Once adjustments have been completed, replace the upper and lower cover plates, lower the infeed and outfeed surface tables and lock them in place with the table locking handles.
8. Reconnect the power and take a test cut to ensure that the adjustment has been correct.

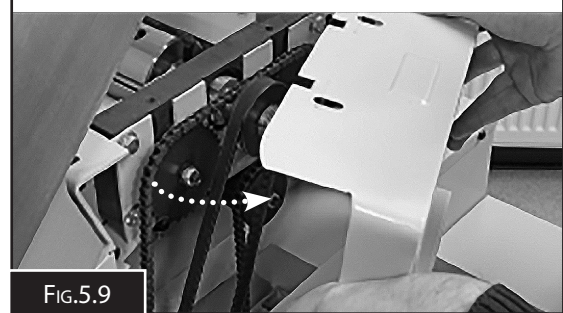

CHAIN DRIVE

The chain drive is adjusted before the machine leaves the factory, but may require adjustment after long usage.

To adjust the chain drive the jockey pulley can be moved to the correct tension. (Fig.5.13)

NOTE: Care should be taken when adjusting the jockey pulley and should only be attempted by an experienced service engineer. Incorrect tension may cause the chain to break or damage the sprockets.

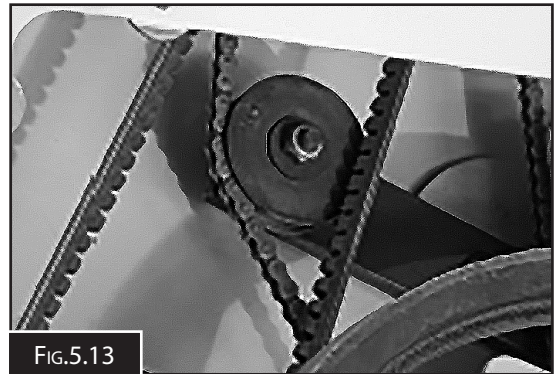

FIG.5.13

5.5 RE-TIGHTENING THE TABLE LOCK DOWN HANDLES.

If the table lock downs becomes loose they can be adjusted by altering the height of the table lock stud.

Hold the stud firmly and loosen the lock nut, adjust the stud, lightly 'pinch' with the lock nut, and try. ("A" in Fig.5.13)

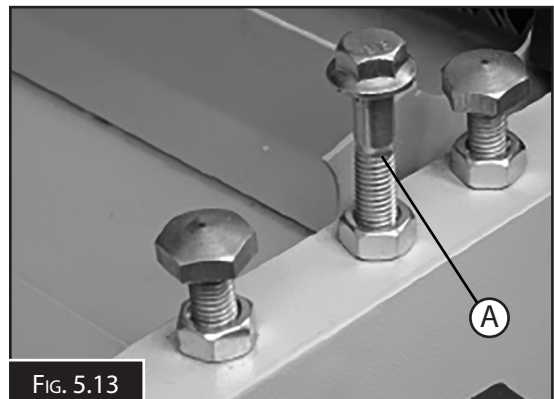

FIG. 5.13

The infeed roller and outfeed roller are those parts of the planer that feed the stock while it is being planed. The infeed roller and the outfeed roller are under spring tension and this tension must be sufficient to feed the stock uniformly through the planer without slipping but should not be so tight that it causes damage to the board. The tension should be equal at both ends of each roller.

To adjust the spring tension of the infeed and outfeed rollers,

Loosen the nuts (one each side of in feed roller) until the spring just becomes loose.

Then loosen the nuts on each side one more full turn. This should produce enough pressure to prevent slippage and not mark the timber. (Fig. 5.14)

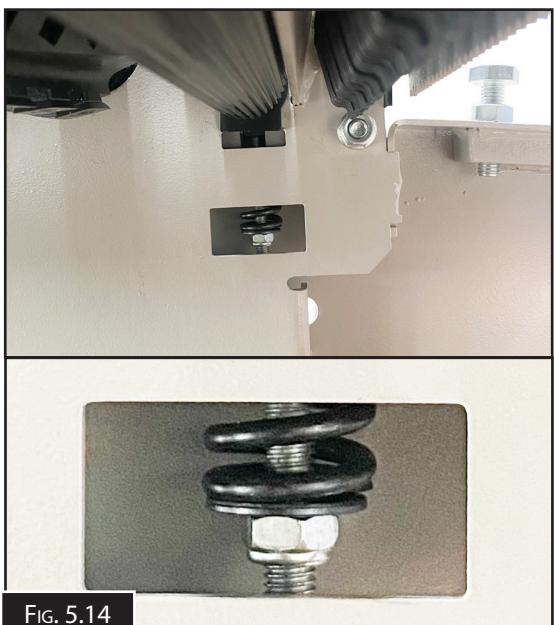

FIG. 5.14

SPARE PARTS SECTION

PLANER THICKNESSER

Models

PT-254S, PT-305S

Order Code W611, Order Code W612

Edition No : 2

Date of Issue : 11/2025

The following section covers the spare parts diagrams and lists that were current at the time this manual was originally printed. Due to continuous improvements of the machine, changes may be made at any time without notification.

HOW TO ORDER SPARE PARTS

1. Have your machines **model number, serial number & date of manufacture** on hand, these can be found on the specification plate mounted on the machine
2. A scanned copy of your parts list/diagram with required spare part/s identified.

NOTE: SOME PARTS MAY ONLY BE AVAILABLE AS AN ASSEMBLY

3. Go to www.machineryhouse.com.au/contactus and fill out the inquiry form attaching a copy of scanned parts list.

CONTENTS

PT-254S SPARE PARTS	35
PT-305S SPARE PARTS.....	47

PT-254S SPARE PARTS DIAGRAM A

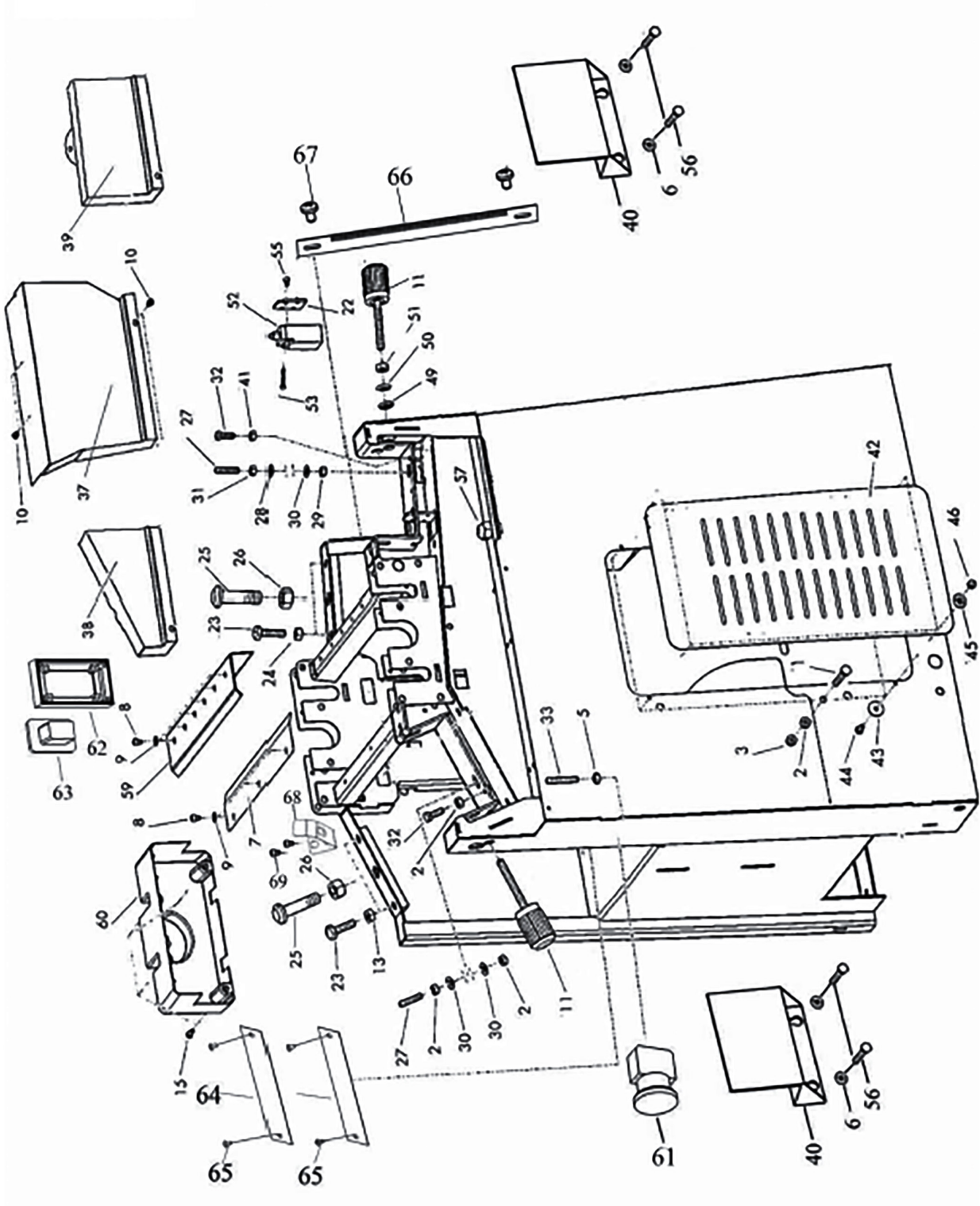

PT-254S PARTS LIST DIAGRAM A

No.	Description	No.	Description
A-1	Screw hex head M8x45	A-32	Screw hex head M8x25
A-2	Nut hex M8	A-33	Set screw M8x50
A-3	Nut hex,lock M8	A-37	Guard,belt
A-5	Nut hex M8	A-38	Guard belt,left
A-6	Pan head screw M6x10	A-39	Guard belt,right
A-7	Cover plate,feed roller	A-40	Cover,terminal box
A-8	Allen screw M6x10	A-41	Nut hex M8
A-9	Spring washer 6mm	A-42	Cover plate,friction wheel
A-10	Pan head screw M6x10	A-43	Flat washer 6mm
A-11	Adjust handle, planer table	A-44	Screw hex head M6x12
A-15	Pan head screw M6x30	A-45	Flat washer 6mm
A-16	Nut hex M6	A-46	Cap nut M7
A-17	Cover plate,control panel	A-49	Wave washer
A-18	Emergency-off button	A-50	Wave washer
A-19	Planer-off button	A-51	Nut hex M10
A-20	Planer-on button	A-52	Limit switch
A-21	Control panel	A-54	Pan head screw M4x30
A-22	Connection Plate,Micro Switch	A-55	Allen screw M5x10
A-23	Stop screw,table	A-56	Pan head screw M6x8
A-24	Nut hex M10	A-57	Strain relief
A-25	Lock screw,table	A-58	Transport retainer
A-26	Nut hex M16	A-59	Guard cover,feed roller
A-27	Set screw M8x40	A-60	Plastic Gear cover
A-28	Washer 8mm	A-63	Power Switch
A-29	Nut hex M8	A-64	Fence bracket
A-30	Washer 8mm	A-65	Flat washer
A-31	Nut hex M8	A-66	Pan head screw M8x12
		A-67	Stop spring plate
		A-68	Pan head screw M5x8

PT-254S SPARE PARTS DIAGRAM B

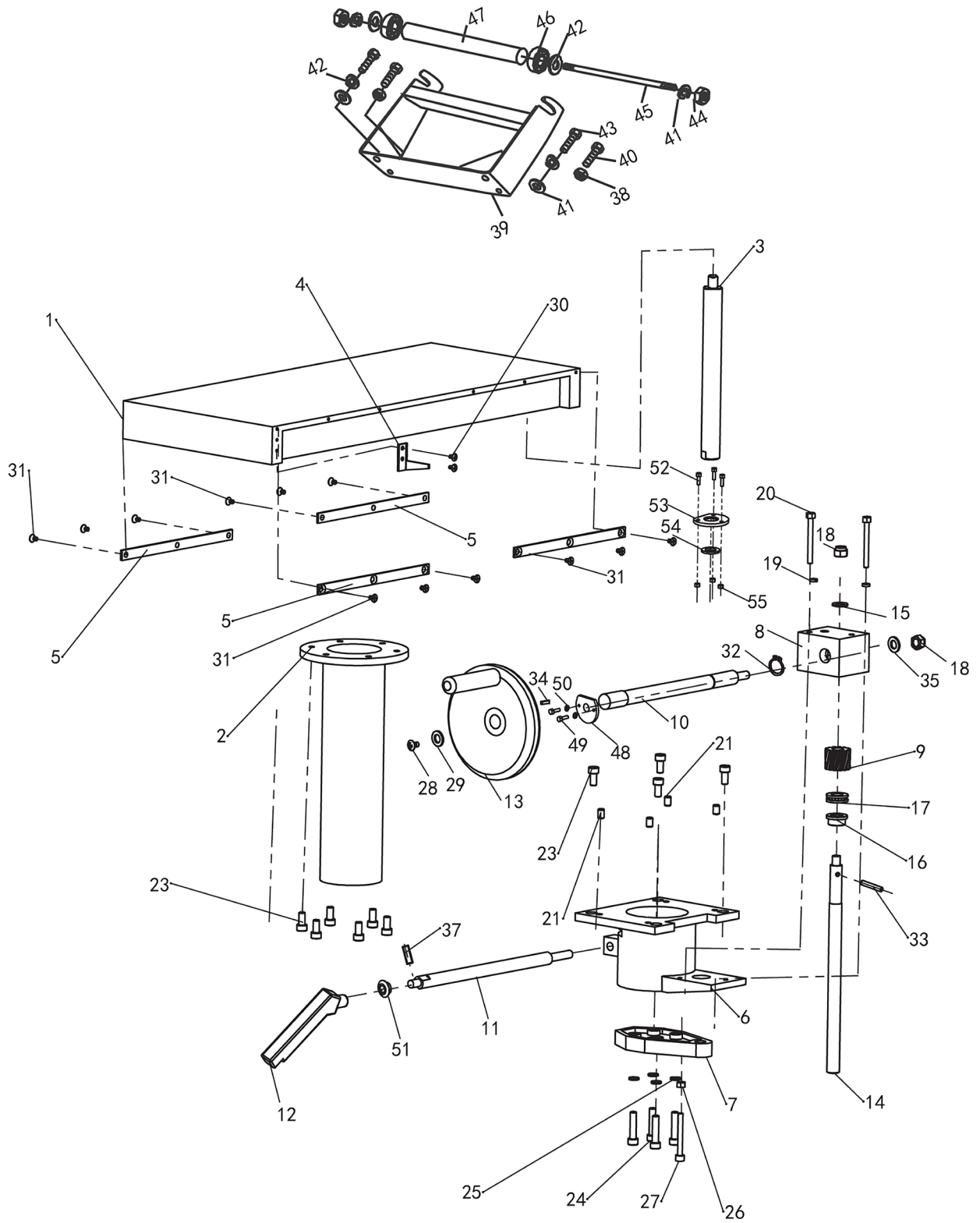

PT-254S PARTS LIST. DIAGRAM B

No.	Description	No.	Description
B-2	Rise and fall clamp lever	B-30	Nut hex M8
B-3	Screw hex head M6x16	B-31	Scale rule
B-4	Allen screw M10x50	B-32	Washer 6mm
B-5	Cone gear A	B-33	Spring washer 6mm
B-6	Cone gear B	B-34	Screw hex head M6x16
B-8	Raise guide rail	B-35	Roll pin 6x22
B-9	Collar stop	B-36	Scale,body
B-10	Rise and fall shaft	B-37	Flat washer 6mm
B-11	Bearing 6003	B-40	Collar,stop
B-12	Pan head screw M6x12	B-41	Set screw M6x6
B-13	Fixed guide rail	B-42	Set screw M6x6
B-14	Raise and fall guide rod	B-44	Support roller
B-15	Bush for rise and fall guide rod	B-45	Hex head screw M8x25
B-16	Bearing 6303	B-46	Washer 10mm
B-17	Washer 8mm	B-47	Spring washer 10mm
B-18	Pan head screw M6x12	B-48	Hex head screw M10x30
B-19	Ring circle	B-49	Hex nut M10
B-20	Handle-wheel	B-50	Spring washer 10mm
B-25	Insert,table bolt	B-51	Washer 10mm
B-26	Nut adjust	B-52	Threaded rod
B-27	Wave washer	B-53	Bearing 6202
B-28	Special thread	B-54	Roller
B-29	Thin washer	B-55	Key
		B-56	Flat washer 8mm
		B-57	Hex.bolt M6

PT-254S SPARE PARTS DIAGRAM C

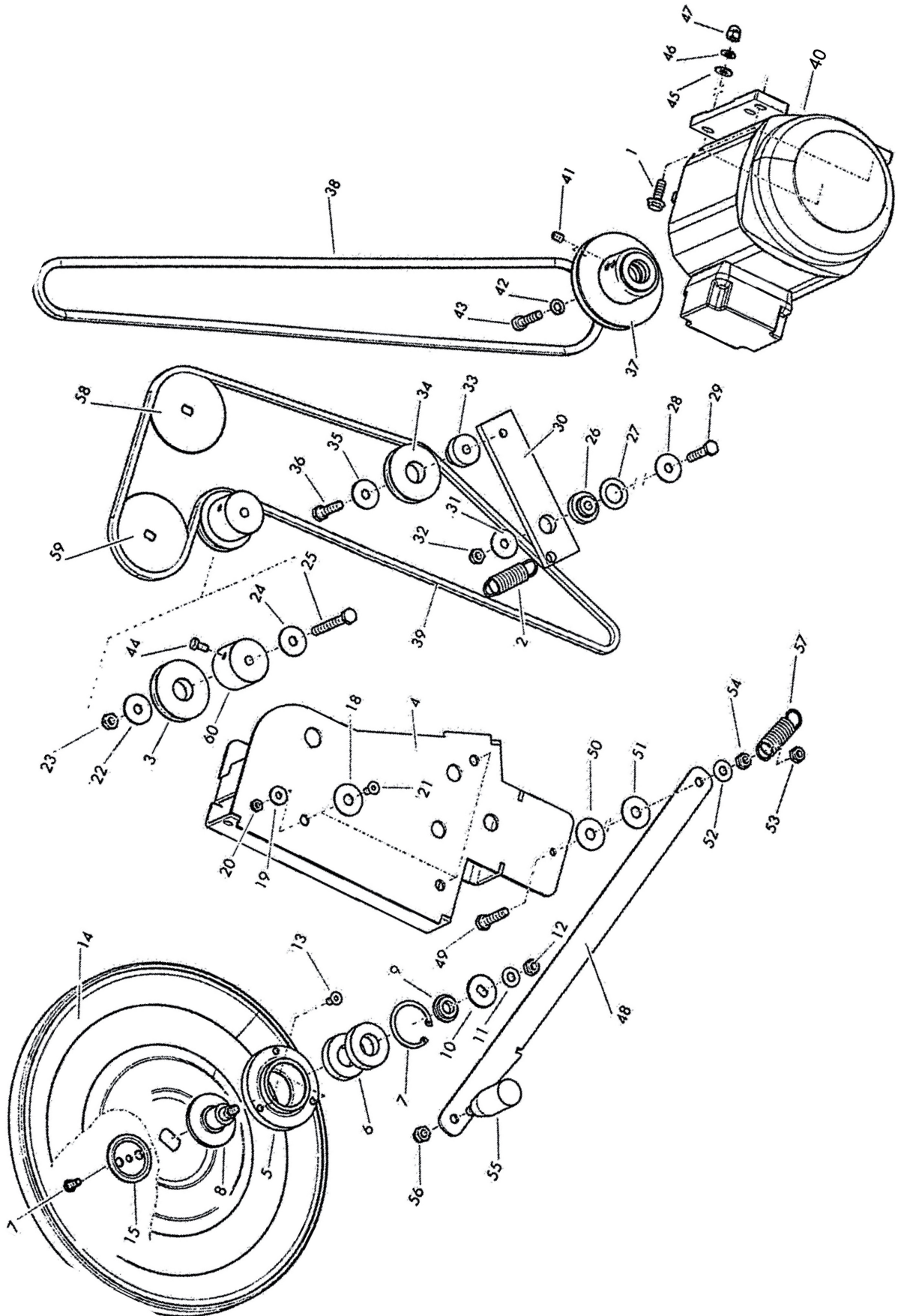

PT-254S PARTS LIST. DIAGRAM C

No.	Description	No.	Description
C-1	Screw hex w/flange M8x25	C-31	Flat washer 8mm
C-2	Pull spring	C-32	Lock nut M8
C-3	Tension pulley	C-33	Spacer
C-4	Guide friction pulley	C-34	Tension pulley
C-5	Spacer lock	C-35	Flat washer 8mm
C-6	Ball bearing 6004-2Z	C-36	Hex head screw M8x45
C-7	Circle ring 42mm	C-37	Motor pulley
C-8	Shaft friction pulley	C-38	Drive belt XPZ 1250
C-9	Spacer,friction pulley	C-39	Drive chain 05B-1-172
C-10	Sprocket B	C-40	Motor
C-11	Flat washer 8mm	C-41	Set screw M8x10
C-12	Lock nut M8	C-42	Spring washer 6mm
C-13	Sunk head screw M6x16	C-43	Allen screw M8x40
C-14	Friction Pulley	C-44	Hex head screw M6x16
C-15	Ring	C-45	Special washer 8mm
C-17	Screw hex head M6x12	C-46	Spring washer 6mm
C-18	Nylon ring	C-47	Cap nut M8
C-19	Washer 6mm	C-48	Lever,friction pulley
C-20	Lock nut M6	C-49	Hex head screw M8x45
C-21	Sunk head screw M6x16	C-50	Plastic washer
C-22	Flat washer 8mm	C-51	Plastic washer
C-23	Lock nut M8	C-52	Flat washer 8mm
C-24	Flat washer 8mm	C-53	Lock nut M8
C-25	Screw hex head M8x70	C-54	Lock nut M8
C-26	Collar	C-55	Lever handle
C-27	Plastic washer	C-56	Cap nut M8
C-28	Flat washer 8mm	C-57	Pull spring
C-29	Hex head screw M8x45	C-58	Sprocket A
C-30	Tension plate	C-59	Sprocket A
		C-60	Shaft tension pulley

PT-254S SPARE PARTS DIAGRAM D

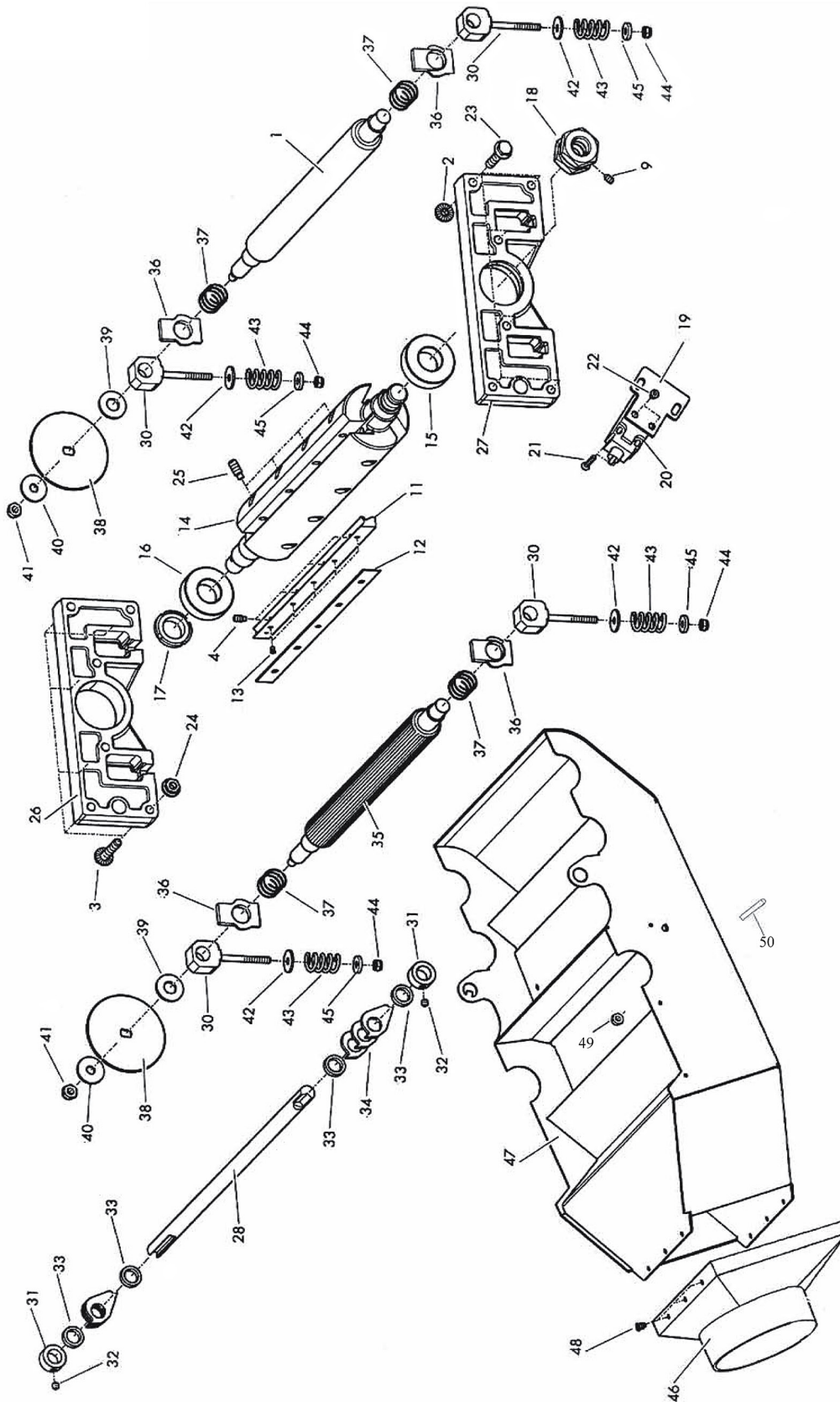

PT-254S PARTS LIST. DIAGRAM D

No.	Description	No.	Description
D-1	Outfeed roller	D-32	Set screw M6x6
D-2	Nut hex w/flange M8	D-33	Spacer
D-3	Screw hex w/flange M8x40	D-34	Recoil lock
D-4	Set screw M6x12	D-35	Infeed roller
D-9	Set screw M6x10	D-36	Square spacer
D-11	Blade holder	D-37	Pressure spring
D-12	Cutter Blade	D-38	Sprocket A
D-14	Cutter block	D-39	Spacer sprocket
D-15	Deep groove bearing 6205-P5-2Z	D-40	Flat washer 8mm
D-16	Deep groove bearing 6205-P5-2Z	D-41	Lock nut M8
D-17	Lock nut for block	D-42	Flat washer 6mm
D-18	Spindle special Hex nut	D-43	Pressure spring for rollers
D-19	Mount,limit switch	D-44	Lock nut M6
D-20	Limit switch	D-45	Flat washer 6mm
D-21	Sunk head screw M4x35	D-46	Dust port
D-22	Nut hex M4	D-47	Combined vacuum hood
D-23	Screw hex w/flange M8x40	D-48	Rivet
D-24	Nut hex w/flange M8	D-49	Pan head screw M4x16
D-25	Set screw for block M8x20	D-50	Seat,locking shaft
D-26	Bearing house,rear	D-51	locking shaft
D-27	Bearing house,front	D-52	Spring
D-28	Shaft,dust hood	D-53	Nut M6
D-30	Glide piece	D-54	Locking plate
D-31	Collar	D-55	Cross sunk head screw M4x12

PT-254S SPARE PARTS DIAGRAM E

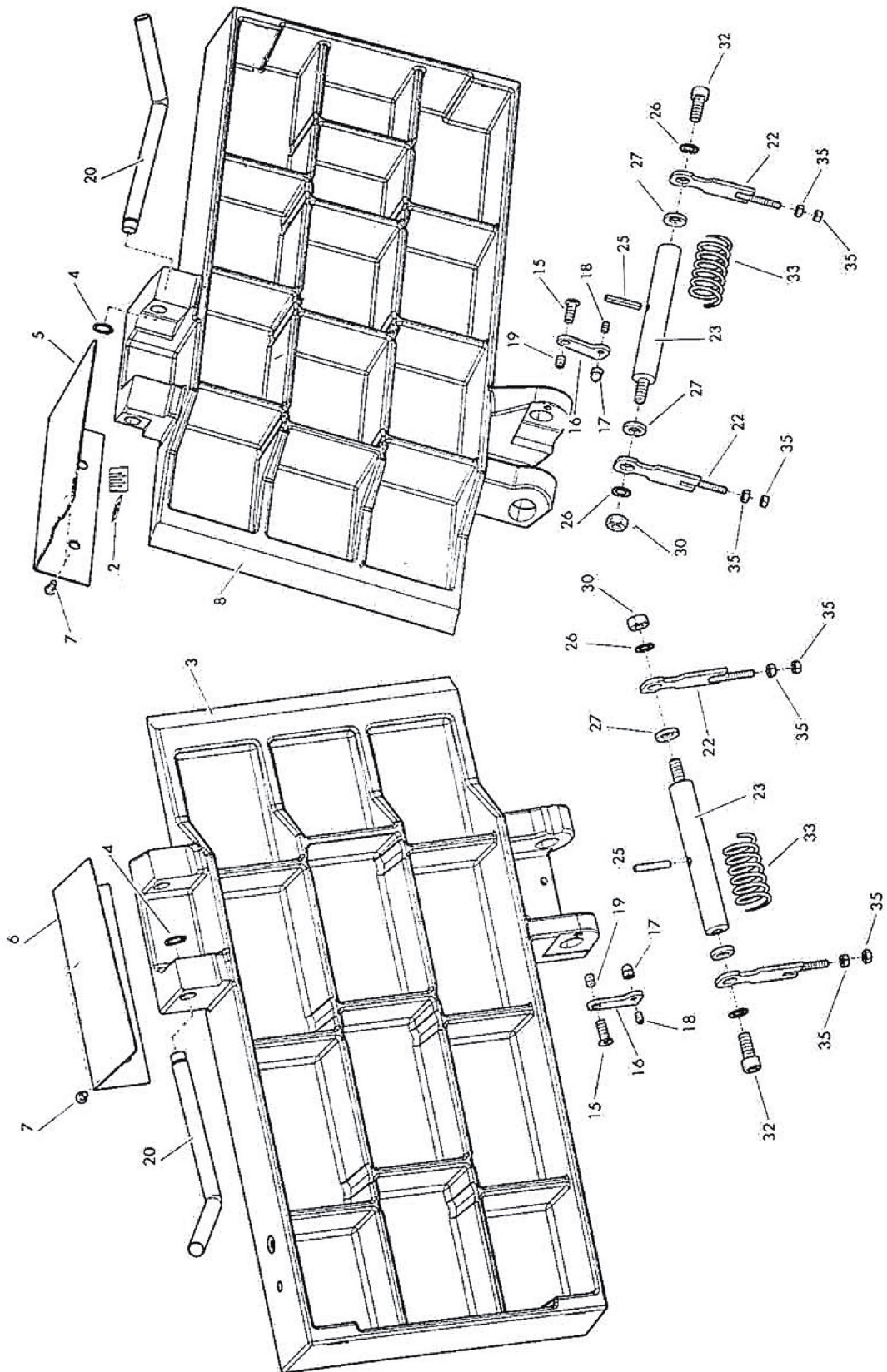

PT-254S PARTS LIST. DIAGRAM E

No.	Description	No.	Description
E-2	Indicator scale	E-19	Set screw M6x6
E-3	Out-feed table	E-20	Clamping lever
E-4	Circle ring 15mm	E-22	Slide piece from table
E-5	Guard,in-feed table	E-23	In-Out feed table shaft
E-6	Guard,out-feed table	E-25	Roll pin 6x35
E-7	Pan head screw M6x12	E-26	External lock washer 10mm
E-8	In-feed table planer	E-27	Wave washer
E-15	Screw	E-30	Nut hex M10
E-16	Bracket	E-32	Allen screw M10x35
E-17	Cap nut M6	E-33	Spring
E-18	Set screw M6x10	E-35	Nut hex M6

PT-254S SPARE PARTS DIAGRAM F

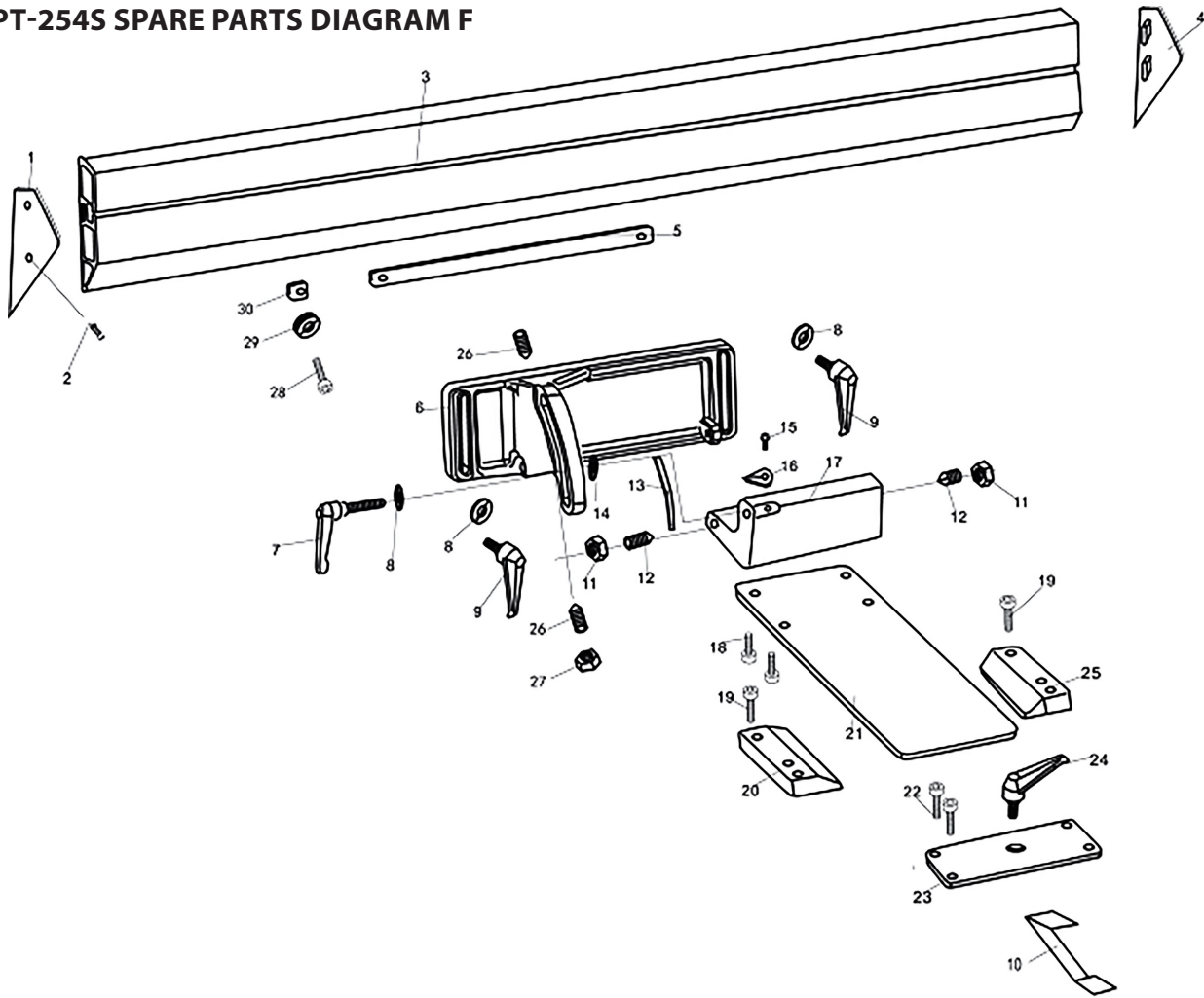

PT-254S PARTS LIST. DIAGRAM F

No.	Description	No.	Description
F-1	Left Hand Cover For Fence	F-16	Pointer
F-2	Pan Head Screw	F-17	Fence block
F-3	Rip Fence	F-18	Allen bolt
F-4	Right Hand Cover For Fence	F-19	Allen bolt
F-5	Connection Plate	F-20	Left fixing plate
F-6	Fence Plate	F-21	Sliding plate
F-7	Adjusting Handle	F-22	Allen screw
F-8	Washer	F-23	Clamping plate
F-9	Adjusting Handle	F-24	Adjusting handle
F-10	Insert Board For Fence	F-25	Right fixing plate
F-11	Nut	F-26	Locking screw M6x12
F-12	Set Screw	F-27	Nut M6
F-13	Scale	F-28	Cross sunk head screw M6x12
F-14	Set Screw	F-29	Stop spacer
F-15	Pan Head Screw	F-30	Locking plate

PT-254S SPARE PARTS DIAGRAM G

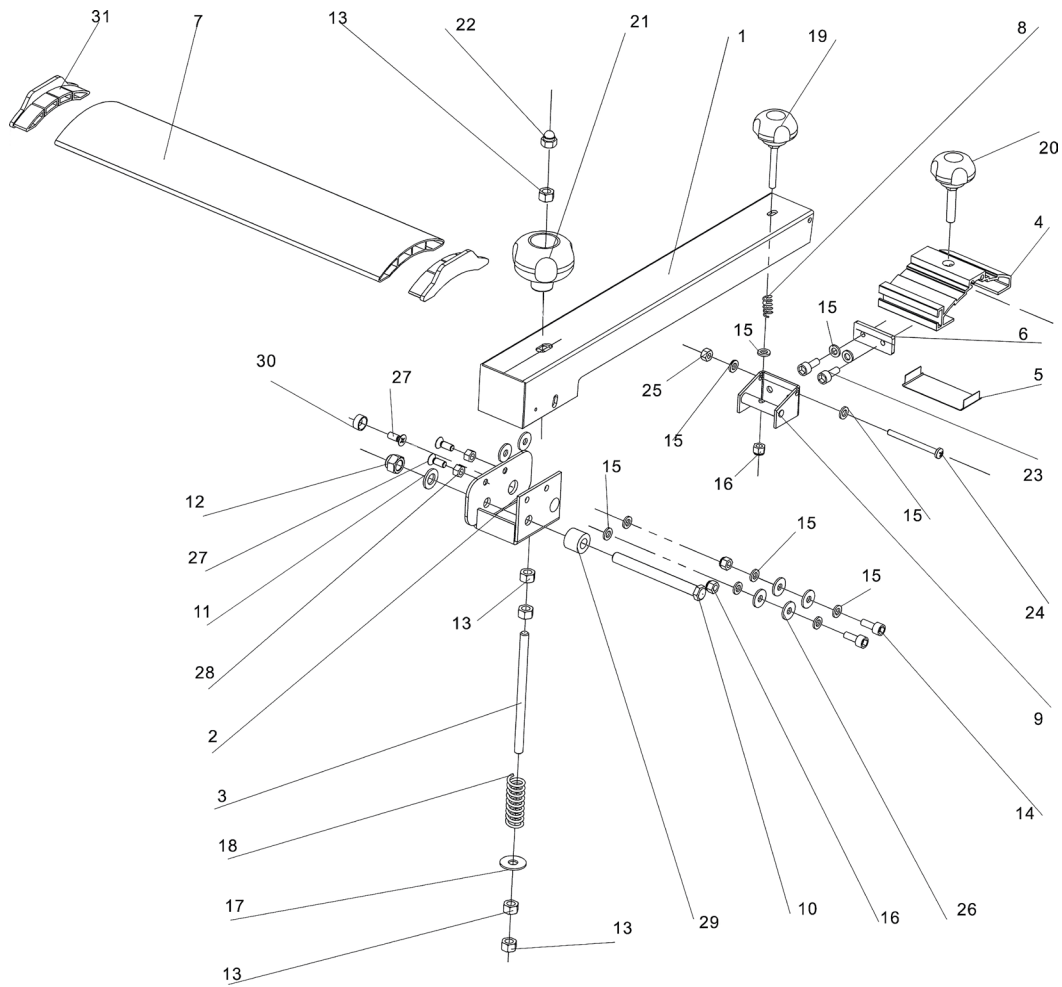

PT-254S PARTS LIST. DIAGRAM G

No.	Description	No.	Description
G-1	Bridge guard arm	G-16	Hex lock nut M6
G-2	Swivel base,guard	G-17	Flat washer 8mm
G-3	Rod,spring	G-18	Spring for guard
G-4	Joint,bridge guard	G-19	Star knob screw M6x35
G-5	Insert for guard	G-20	Star knob screw M8x35
G-6	Bolt guide	G-21	Star knob for guard
G-7	Protective guard plate	G-22	Cap nut M8
G-8	Spring	G-23	Allen screw M6x10
G-9	Knot	G-24	Pan head screw M5x65
G-10	Hex head screw M10x100	G-25	Hex lock nut M6
G-11	Washer 10mm	G-26	Spacer
G-12	Hex lock nut M10	G-27	Cross sunk head screw M6x16
G-13	Hex nut M8	G-28	Hex lock nut M6
G-14	Allen screw M6x20	G-29	Spacer
G-15	Washer 6mm	G-30	Spacer
		G-31	End cap guard

PT-305S PARTS LIST. DIAGRAM A

No.	Description	No.	Description
A-1	Screw hex head M8x45	A-32	Screw hex head M8x25
A-2	Nut hex M8	A-33	Set screw M8x50
A-3	Nut hex,lock M8	A-37	Guard,belt
A-5	Nut hex M8	A-38	Guard belt,left
A-6	Pan head screw M6x10	A-39	Guard belt,right
A-7	Cover plate,feed roller	A-40	Cover,terminal box
A-8	Allen screw M6x10	A-41	Nut hex M8
A-9	Spring washer 6mm	A-42	Cover plate,friction wheel
A-10	Pan head screw M6x10	A-43	Flat washer 6mm
A-11	Adjust handle, planer table	A-44	Screw hex head M6x12
A-15	Pan head screw M6x30	A-45	Flat washer 6mm
A-16	Nut hex M6	A-46	Cap nut M7
A-17	Cover plate,control panel	A-49	Wave washer
A-18	Emergency-off button	A-50	Wave washer
A-19	Planer-off button	A-51	Nut hex M10
A-20	Planer-on button	A-52	Limit switch
A-21	Control panel	A-54	Pan head screw M4x30
A-22	Connection Plate,Micro Switch	A-55	Allen screw M5x10
A-23	Stop screw,table	A-56	Pan head screw M6x8
A-24	Nut hex M10	A-57	Strain relief
A-25	Lock screw,table	A-58	Transport retainer
A-26	Nut hex M16	A-59	Guard cover,feed roller
A-27	Set screw M8x40	A-60	Plastic Gear cover
A-28	Washer 8mm	A-63	Power Switch
A-29	Nut hex M8	A-64	Fence bracket
A-30	Washer 8mm	A-65	Flat washer
A-31	Nut hex M8	A-66	Pan head screw M8x12
		A-67	Stop spring plate
		A-68	Pan head screw M

PT-305S SPARE PARTS DIAGRAM B

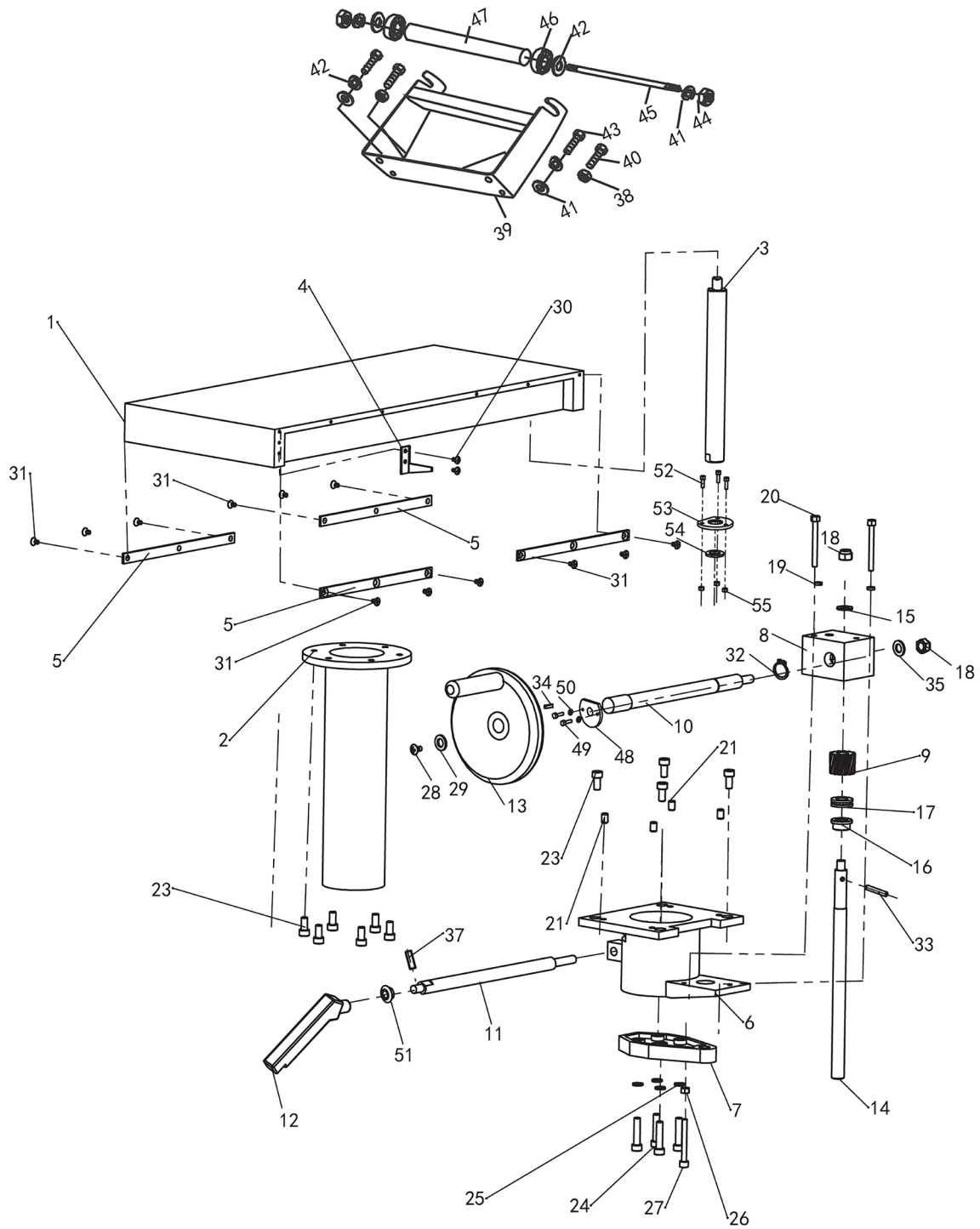

PT-305S PARTS LIST. DIAGRAM B

No.	Description	No.	Description
B-2	Rise and fall clamp lever	B-30	Nut hex M8
B-3	Screw hex head M6x16	B-31	Scale rule
B-4	Allen screw M10x50	B-32	Washer 6mm
B-5	Cone gear A	B-33	Spring washer 6mm
B-6	Cone gear B	B-34	Screw hex head M6x16
B-8	Raise guide rail	B-35	Roll pin 6x22
B-9	Collar stop	B-36	Scale,body
B-10	Rise and fall shaft	B-37	Flat washer 6mm
B-11	Bearing 6003	B-40	Collar,stop
B-12	Pan head screw M6x12	B-41	Set screw M6x6
B-13	Fixed guide rail	B-42	Set screw M6x6
B-14	Raise and fall guide rod	B-44	Support roller
B-15	Bush for rise and fall guide rod	B-45	Hex head screw M8x25
B-16	Bearing 6303	B-46	Washer 10mm
B-17	Washer 8mm	B-47	Spring washer 10mm
B-18	Pan head screw M6x12	B-48	Hex head screw M10x30
B-19	Ring circle	B-49	Hex nut M10
B-20	Handle-wheel	B-50	Spring washer 10mm
B-25	Insert,table bolt	B-51	Washer 10mm
B-26	Nut adjust	B-52	Threaded rod
B-27	Wave washer	B-53	Bearing 6202
B-28	Special thread	B-54	Roller
B-29	Thin washer	B-55	Key
		B-56	Flat washer 8mm
		B-57	Hex.bolt M6

PT-305S SPARE PARTS DIAGRAM C

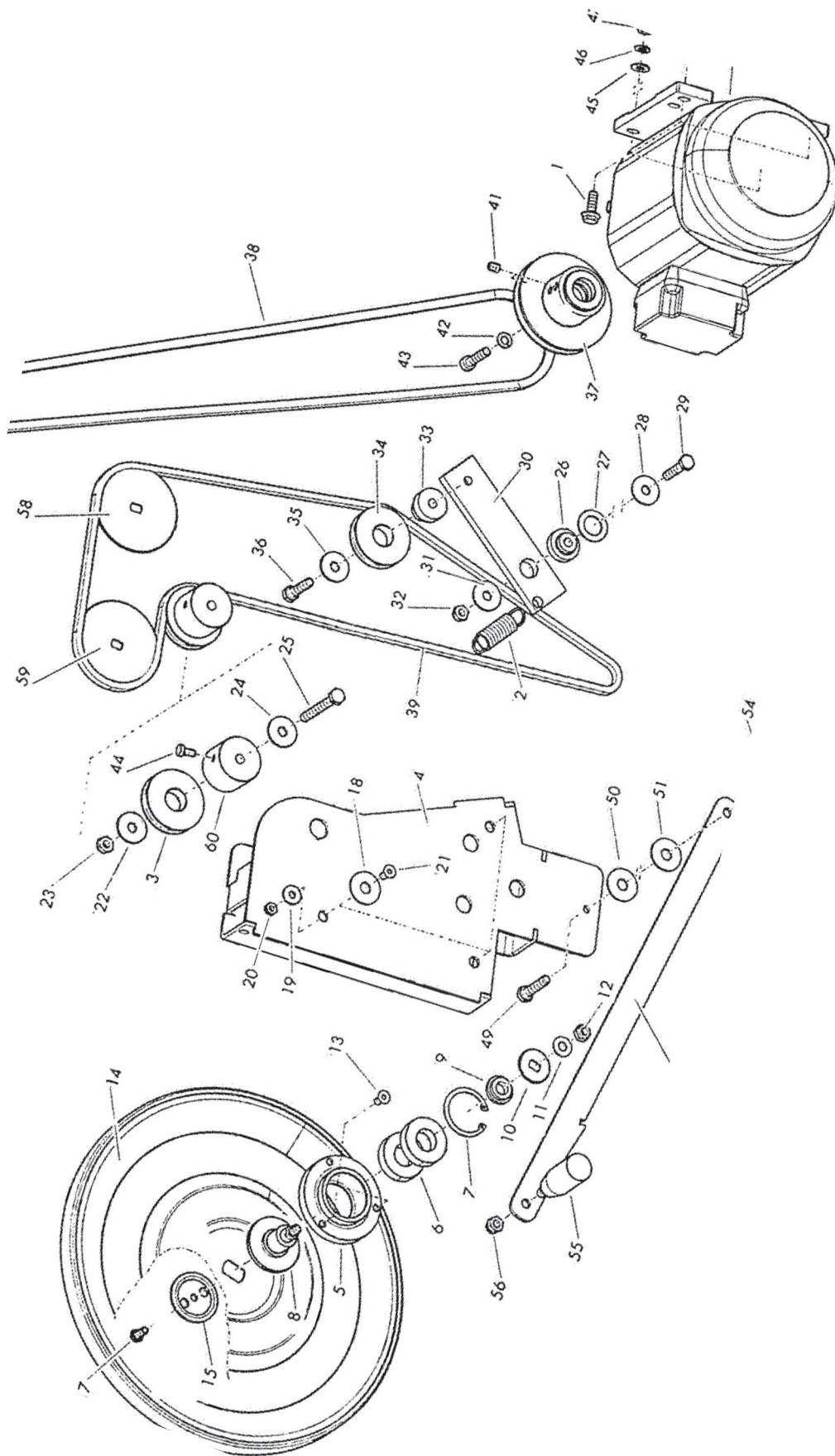

PT-305S PARTS LIST. DIAGRAM C

No.	Description	No.	Description
C-1	Screw hex w/flange M8x25	C-32	Lock nut M8
C-2	Pull spring	C-33	Spacer
C-3	Tension pulley	C-34	Tension pulley
C-4	Guide,friction pulley	C-35	Flat washer 8mm
C-5	Spacer lock	C-36	Hex head screw M8x45
C-6	Ball bearing 6004-2Z	C-37	Motor pulley
C-7	Circle ring 42mm	C-38	Drive belt XPZ 1340/3Vx530
C-8	Shaft friction pulley	C-39	Drive chain 05B-1-172
C-9	Spacer friction pulley	C-40	Motor
C-10	Sprocket B	C-41	Set screw M8x10
C-11	Flat washer 8mm	C-42	Spring washer 6mm
C-12	Lock nut M8	C-43	Allen screw M8x40
C-13	Sunk head screw M6x16	C-44	Hex head screw M6x16
C-14	Friction pulley	C-45	Special washer 8mm
C-15	Ring	C-46	Spring washer 6mm
C-17	Screw hex head M6x12	C-47	Cap nut M8
C-18	Nylon ring	C-48	Lever,friction pulley
C-19	Washer 6mm	C-49	Hex head screw M8x45
C-20	Lock nut M6	C-50	Plastic washer
C-21	Sunk head screw M6x16	C-51	Plastic washer
C-22	Flat washer 8mm	C-52	Flat washer 8mm
C-23	Lock nut M8	C-53	Lock nut M8
C-24	Flat washer 8mm	C-54	Lock nut M8
C-25	Screw hex head M8x70	C-55	Handle for lever
C-26	Collar	C-56	Cap nut M8
C-27	Plastic washer	C-57	Pull spring
C-28	Flat washer 8mm	C-58	Sprocket A
C-29	Hex head screw M8x45	C-59	Sprocket A
C-30	Tension plate	C-60	Shaft,tension pulley
C-31	Flat washer 8m		

PT-305S SPARE PARTS DIAGRAM D

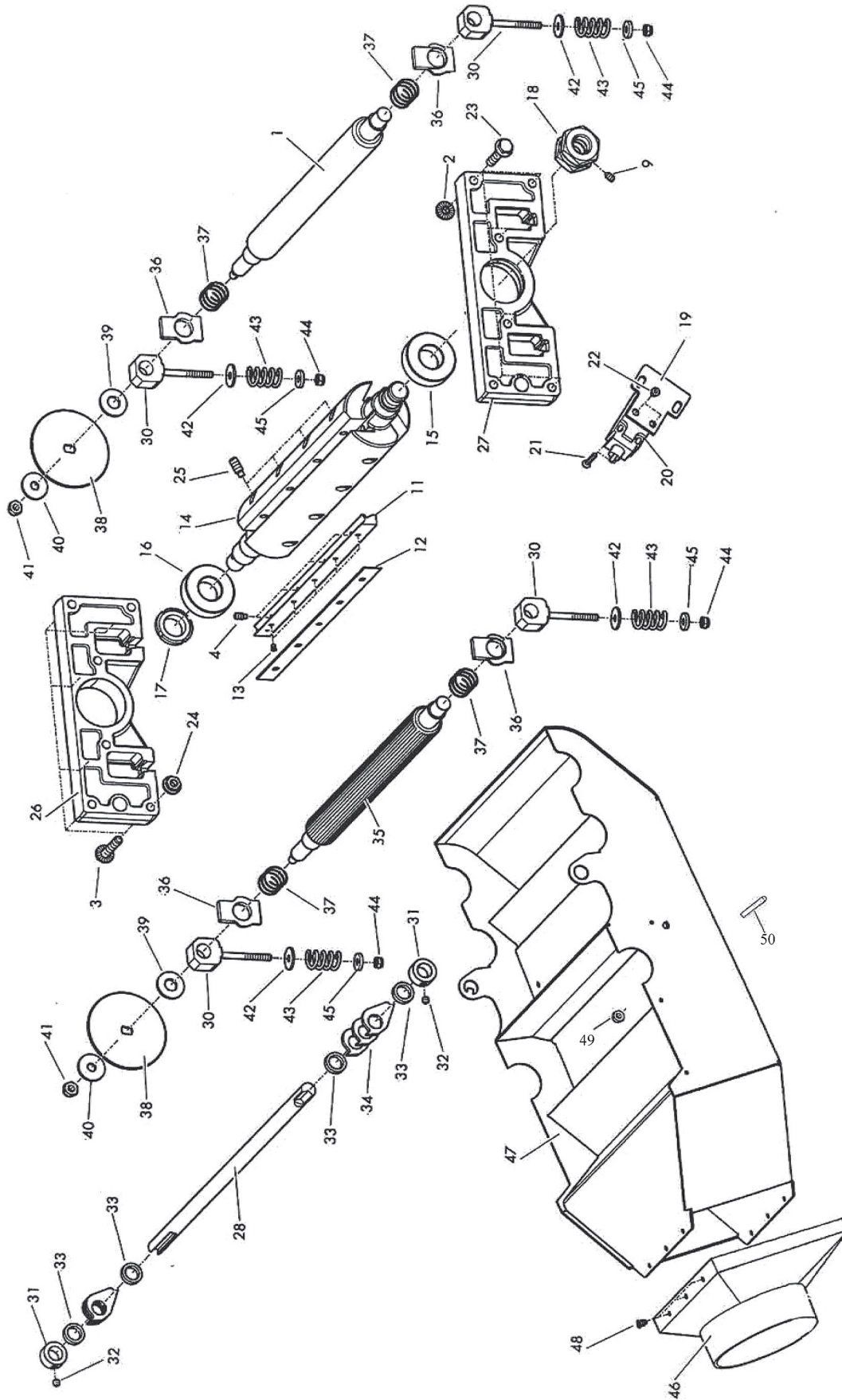

PT-305S PARTS LIST DIAGRAM D

No.	Description	No.	Description
D-1	Outfeed roller	D-27	Bearing house,front
D-2	Nut hex w/flange M8	D-28	Shaft,dust hood
D-3	Screw hex w/flange M8x40	D-30	Glide piece
D-4	Set screw M6x12	D-31	Collar
D-9	Set screw M6x10	D-32	Set screw M6x6
D-11	Blade holder	D-34	Recoil lock
D-12	Cutter blade	D-35	Infeed roller
D-14	Cutter block	D-36	Square spacer
D-15	Deep groove bearing 6205-P5-2Z	D-37	Pressure spring
D-16	Deep groove bearing 6205-P5-2Z	D-38	Sprocket A
D-17	Lock nut for block	D-39	Spacer sprocket
D-18	Spindle special Hex nut	D-40	Flat washer 8mm
D-19	Mount,limit switch	D-41	Lock nut M8
D-20	Limit switch	D-42	Flat washer 6mm
D-21	Sunk head screw M4x35	D-43	Pressure spring
D-22	Nut hex M4	D-44	Lock nut M6
D-23	Screw hex w/flange M8x40	D-45	Flat washer 6mm
D-24	Nut hex w/flange M8	D-46	Dust port
D-25	Set screw for block M8x20	D-47	Combined vacuum hood
D-26	Bearing house,rear	D-48	Rivet
		D-49	Pan head screw M4x16
		D-50	Locking shaft

PT-305S SPARE PARTS DIAGRAM E

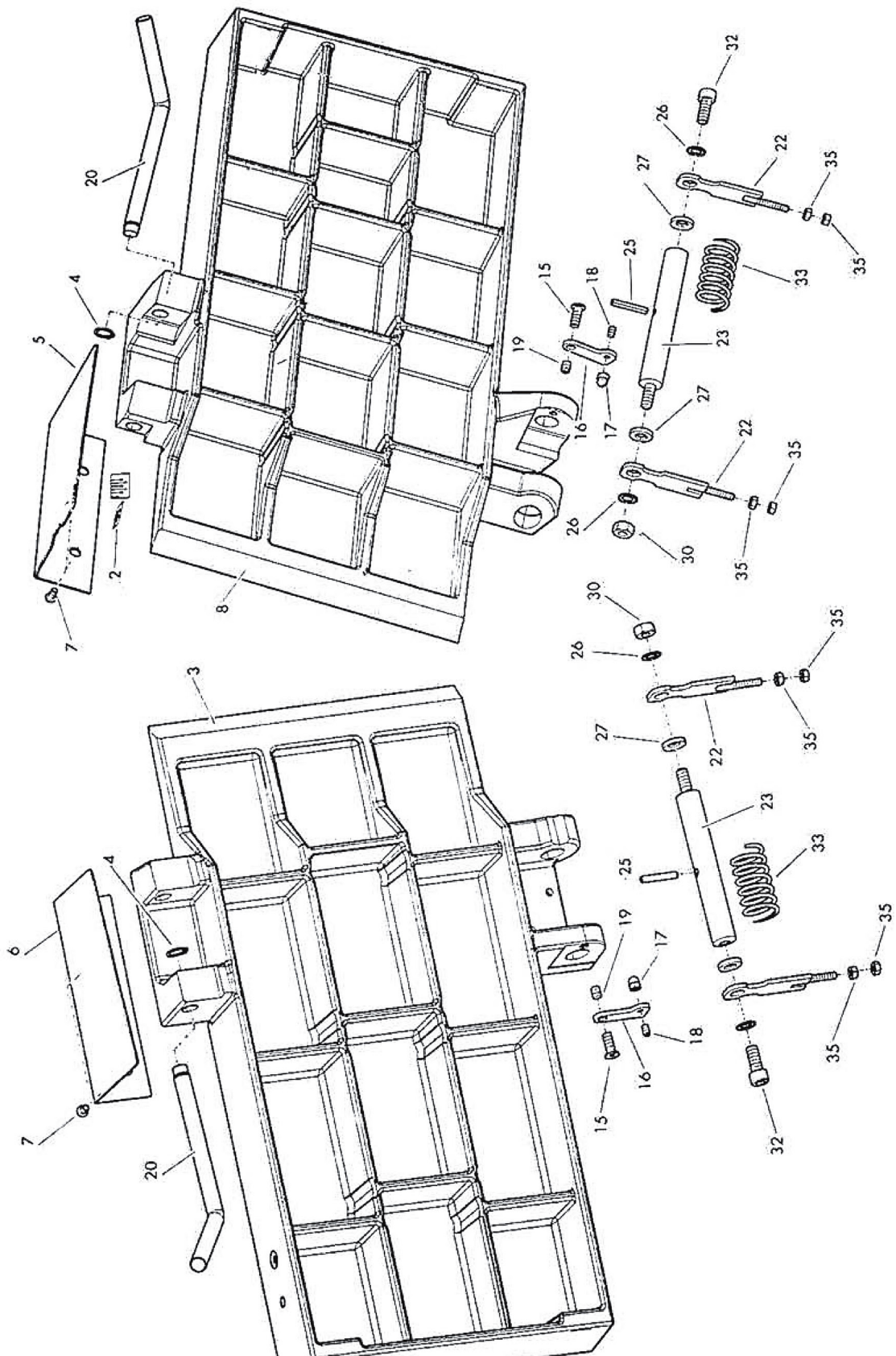

PT-305S PARTS LIST DIAGRAM E

No.	Description	No.	Description
E-2	Indicator scale	E-20	Clamping lever
E-3	Out-feed table	E-21	Table turning handle
E-4	Circle ring 15mm	E-22	Slide piece from table
E-5	Guard,in-feed table	E-23	In-Out feed table shaft
E-6	Guard,out-feed table	E-25	Roll pin 6x35
E-7	Pan head screw M6x12	E-26	External lock washer 10mm
E-8	In-feed table,planer	E-27	Wave washer
E-15	Screw	E-28	Washer 8mm
E-16	Bracket	E-29	Nut hex M8
E-17	Cap nut M6	E-30	Nut hex M10
E-18	Set screw M6x10	E-32	Allen screw M10x35
E-19	Set screw M6x6	E-33	Spring
		E-35	Nut hex M6

PT-305S SPARE PARTS DIAGRAM F

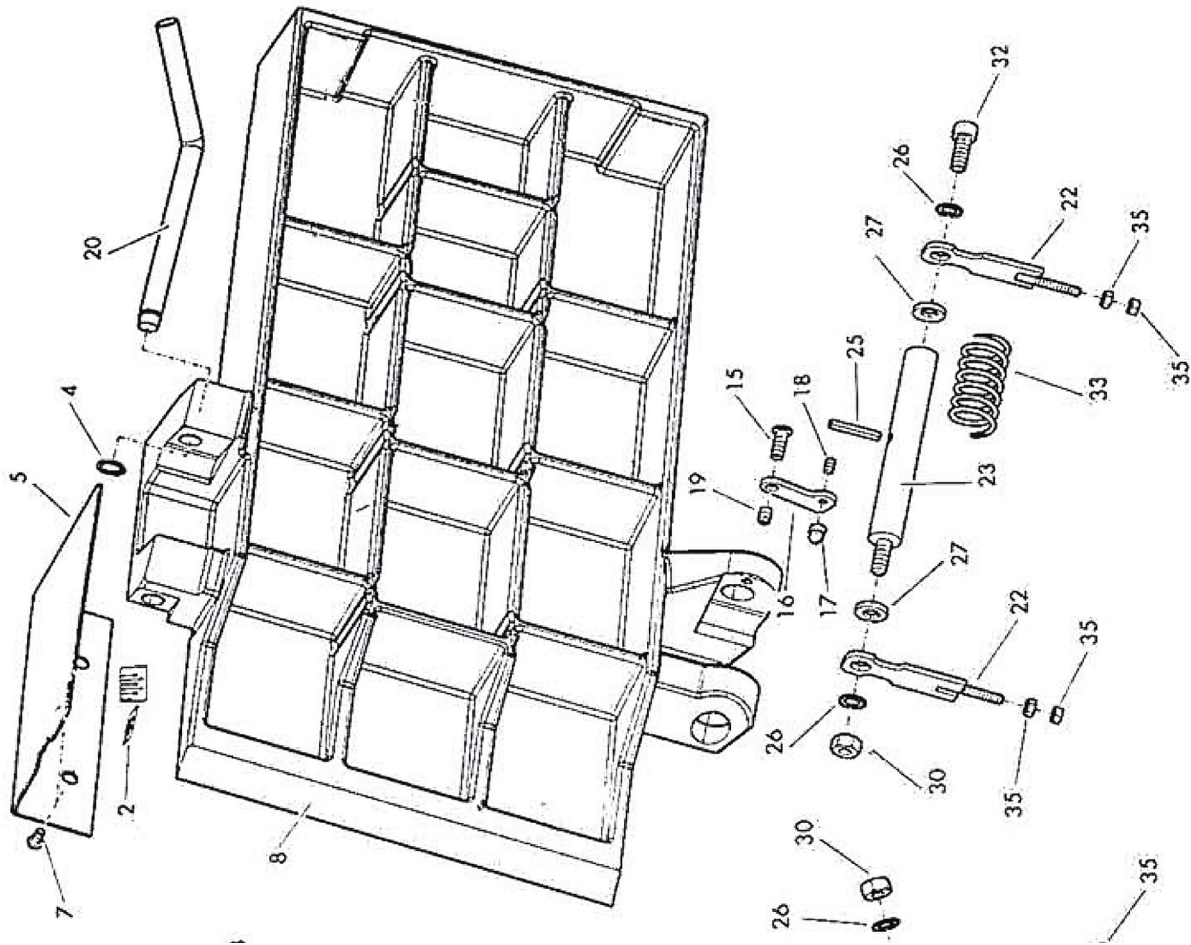

PT-305S PARTS LIST DIAGRAM F

No.	Description	No.	Description
F-1	Nut hex M6	F-22	Swivel base
F-2	Spring	F-23	Large washer
F-3	Flat washer	F-24	Sunk head screw M6x16
F-4	Protective guard plate	F-25	Lock nut M6
F-5	End cap protective guard	F-26	Washer 6mm
F-6	Bridge guard arm	F-27	Allen screw M6x20
F-7	Joint,bridge guard	F-28	Lock nut M6
F-8	Blot guide	F-31	Washer 10mm
F-9	Knot	F-32	Lock nut M6
F-10	Spacer	F-33	Washer 8mm
F-11	Screw rod M8x145	F-34	Lock nut M8
F-12	Screw hex head M10x120	F-35	Set screw M6x12
F-13	Star knob for guard	F-36	Spacer,lock
F-17	Star knob for guard	F-37	Sunk head screw M6x16
F-18	Cap nut M8	F-38	Allen screw M6x10
F-19	Nut hex M8	F-39	Spring
F-20	Nut hex M8	F-40	Hex nut M5
F-21	Nut hex M8,thin	F-41	Washer 5mm
		F-42	Pan head screw M5x60

PT-305S SPARE PARTS DIAGRAM G

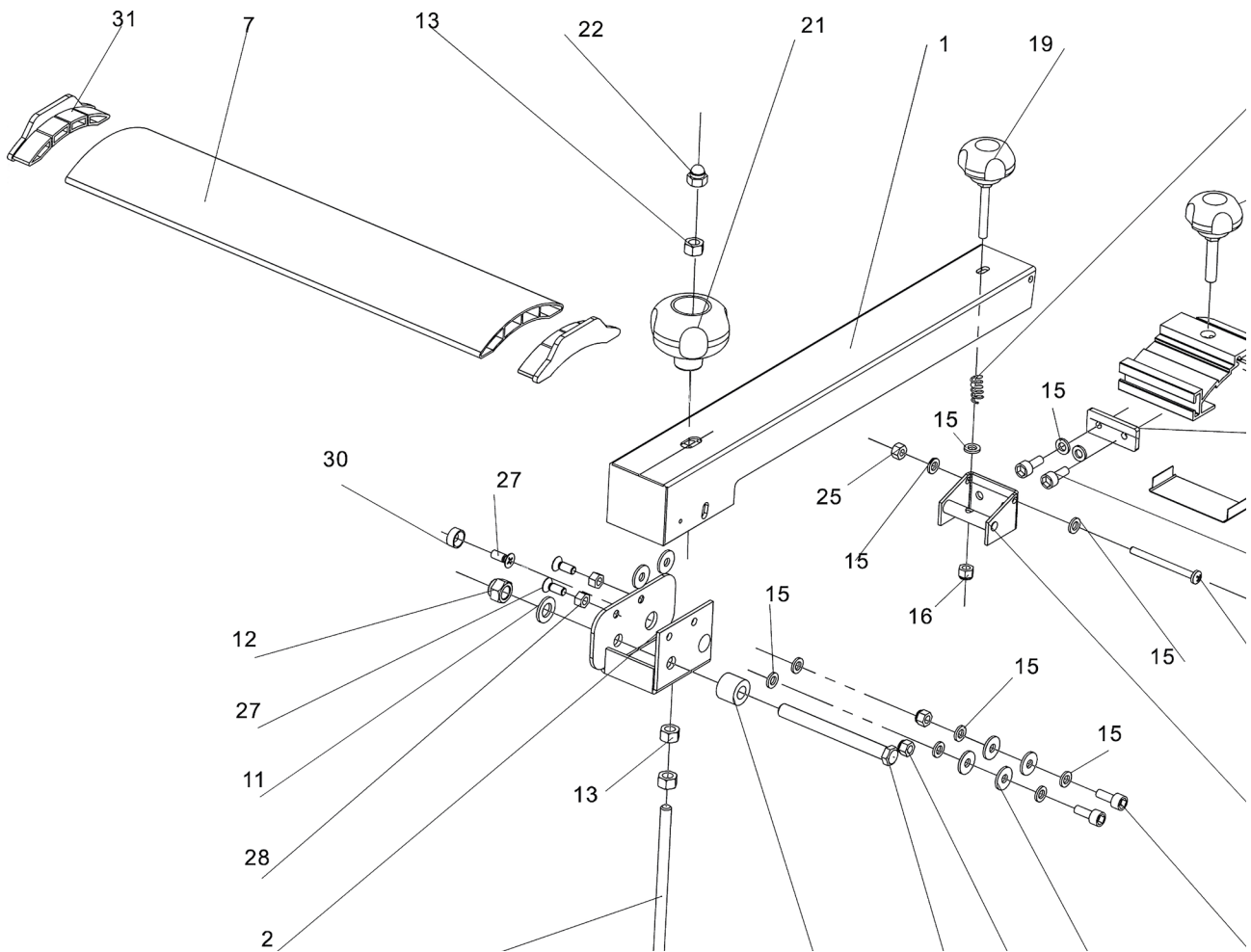

PT-305S PARTS LIST DIAGRAM G

No.	Description	No.	Description
G-1	Left hand cover for fence	G-16	Pointer
G-2	Pan head screw	G-17	Fence block
G-3	Rip fence	G-18	Allen bolt
G-4	Right hand cover for fence	G-19	Allen bolt
G-5	Connection plate	G-20	Left fixing plate
G-6	Fence plate	G-21	Sliding plate
G-7	Adjusting handle	G-22	Allen screw
G-8	Washer	G-23	Clamping plate
G-9	Adjusting handle	G-24	Adjusting handle
G-10	Insert board for fence	G-25	Right fixing plate
G-11	Nut	G-26	Locking screw M6x12
G-12	Set screw	G-27	Nut M6
G-13	Scale	G-28	Cross sunk head screw M6x12
G-14	Set screw	G-29	Stop spacer
G-15	Pan head screw	G-30	Locking plate

PT-254S SPIRAL CUTTER BLOCK

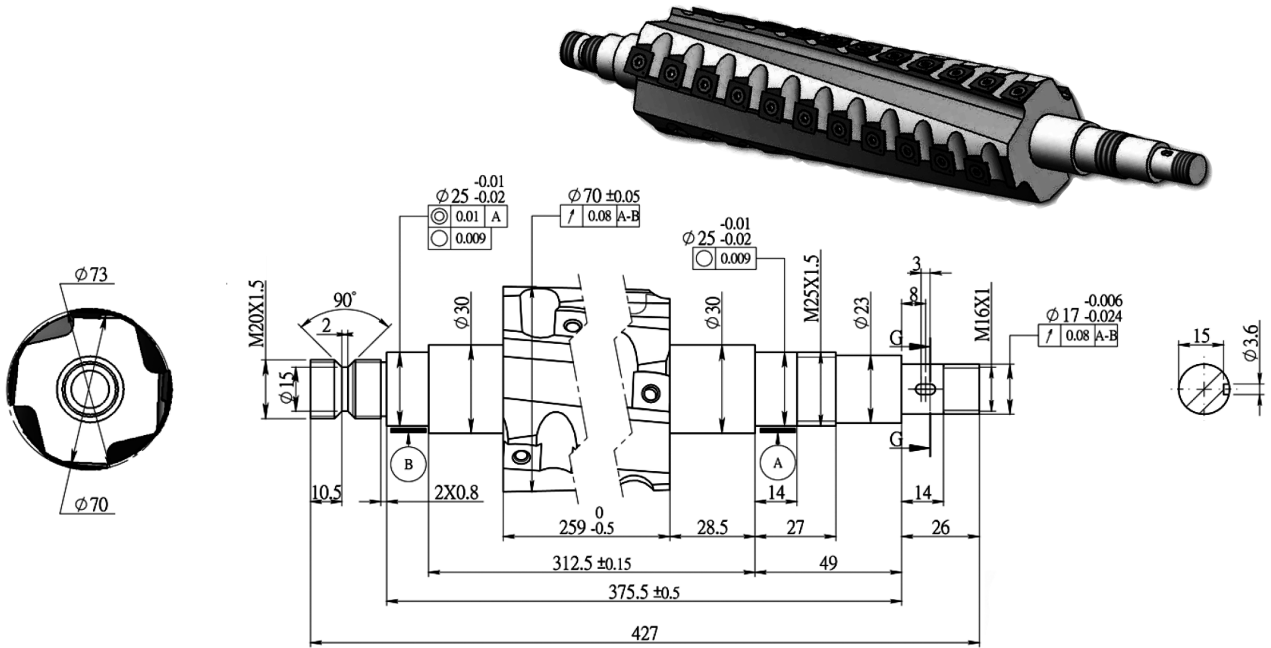

PT-305S SPIRAL CUTTER BLOCK

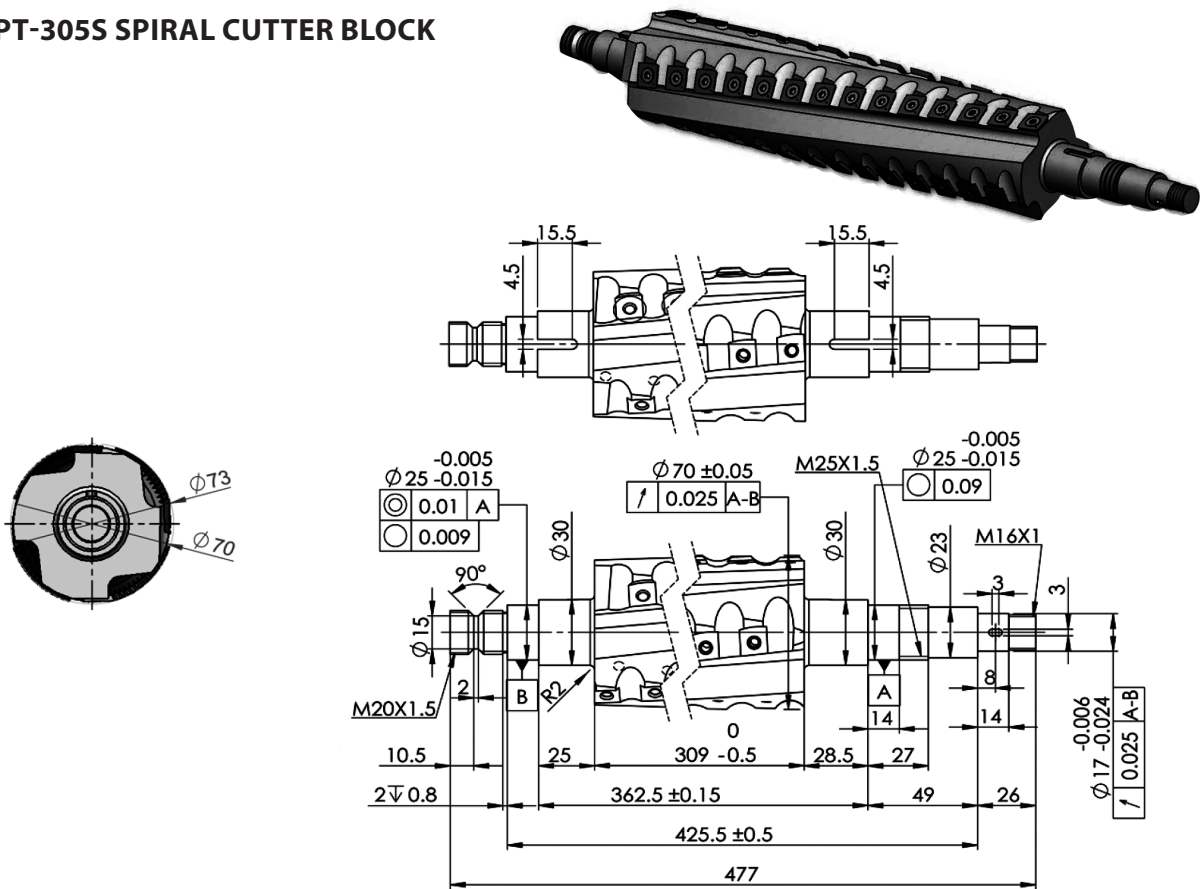

PT-254S ELECTRICAL DIAGRAM

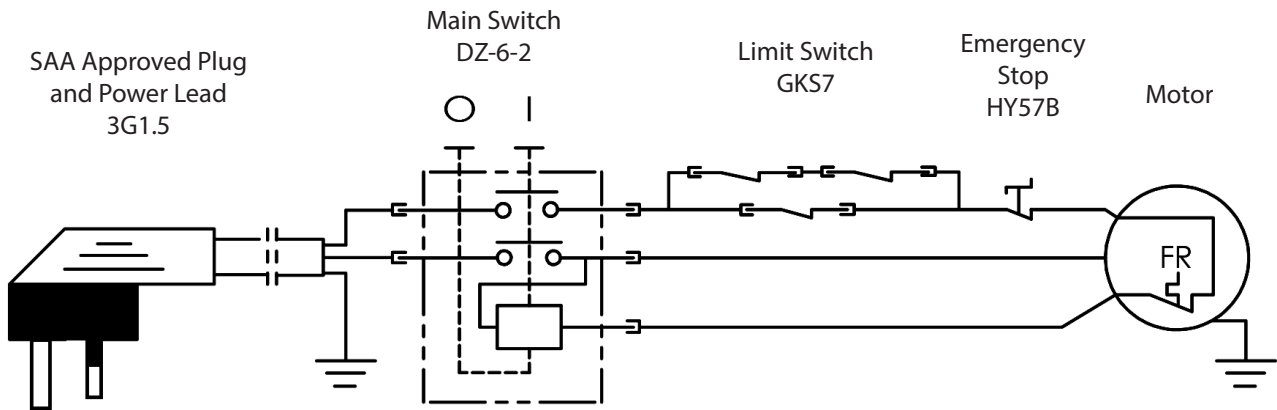

PT-305S ELECTRICAL DIAGRAM

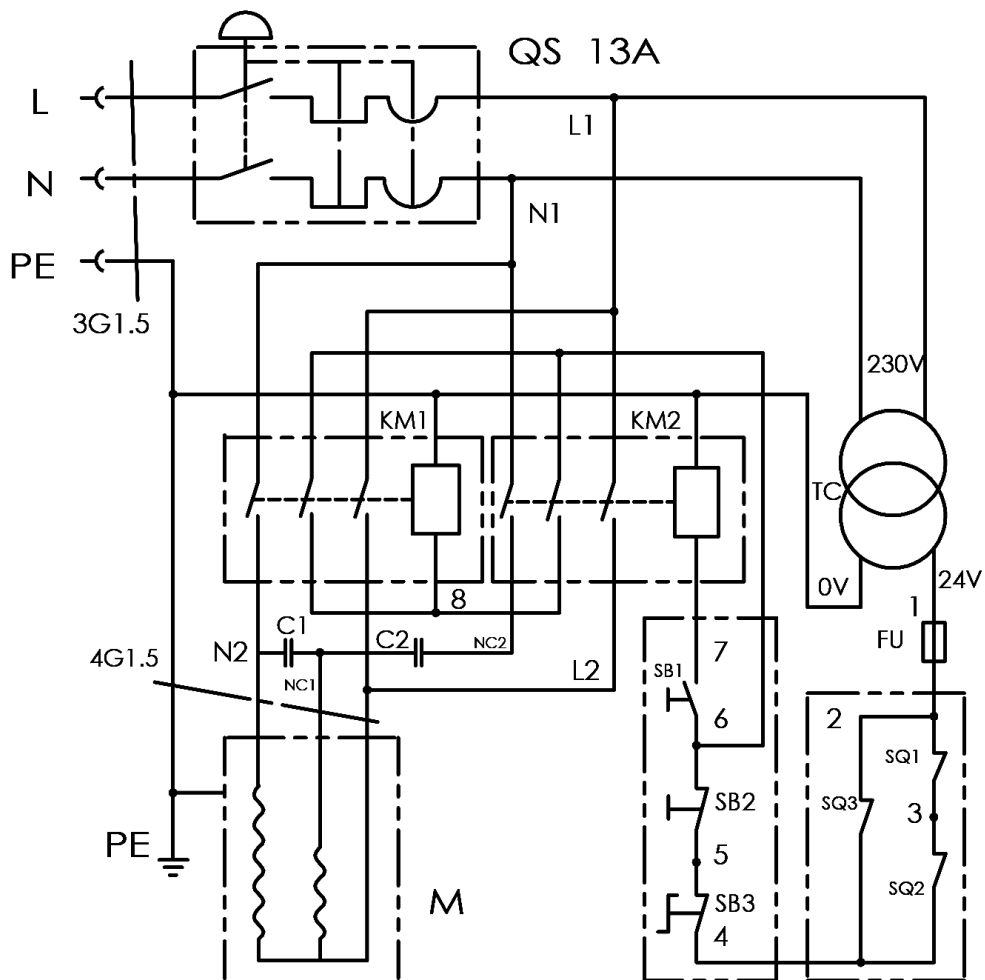

PT-305S ELECTRICAL PARTS LIST

Code	Description	Specification	Qty.
OS	Overload Circuit Breaker	RB6/13A	1
TC	Transformer	BK50 230/24V	1
FU	Fuse	2A	1
SQ01, SQ02, SQ03	Micro Switch	QKS7	3
SB	Start Button	Y090-10S	1
SB2	Stop Button	Y090-01S	1
SB3	Emergency Stop	HY57B	1
KM1, KM2	Contactor	CJX2-1810	2
C1	Running Capacitor	CBB60.40uF.450V	1
C2	Start Capacity	CBB60.150uF.265V	1



ENVIRONMENT PROTECTION

Recycle unwanted materials instead of disposing of them as waste. All tools, accessories and packaging should be sorted, taken to a recycling centre and disposed of in a manner which is compatible with the environment. When the product becomes completely unserviceable and requires disposal, drain any fluids (if applicable) into approved containers and dispose of the product and fluids according to local regulations.

IMPORTED BY



Australian Distributor

**Hare & Forbes
Machineryhouse**
Sydney - Melbourne
Adelaide - Brisbane - Perth

Ph: 1300 202 200
www.machineryhouse.com.au



New Zealand Distributor

Machineryhouse
Auckland
Christchurch

Ph: 0800 142 326
www.machineryhouse.co.nz